

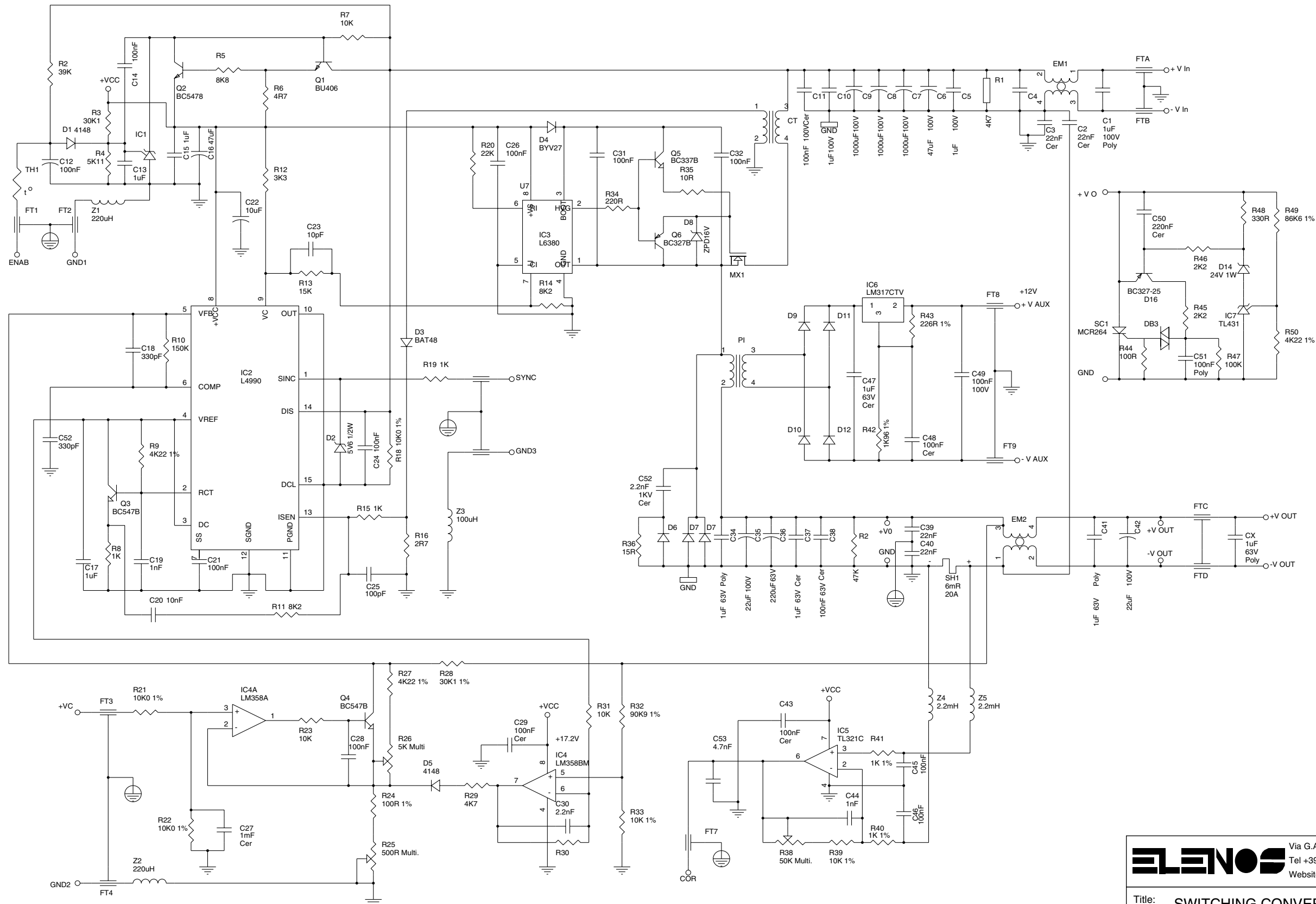

 Via G.Amendola 9 44028 Poggio Renatico (FE) Italy Tel +39 0532 829965 Fax +39 0532 829177 Website WWW.ELENOS.COM		
Title: AUX POWER SUPPLY		
Board Code: ETG-0199-ALI.C	Model: ETG250/300	Rev 1.1
Proj. Engr. : A.Tomassini	Approved : A.Giovannelli	
Date: Wednesday, November 15, 2000	Sheet 1	of 1



 Via G. Amendola 9 44028 Poggio Renatico (FE) Italy Tel +39 0532 829965 Fax +39 0532 829177 Website WWW.ELENOS.COM		
Title: SWITCHING CONVERTER		
Board Code: E13-98AA-ALI.B	Model: ETG250/300	Rev 1
Proj. Engr. : A.Tomassini	Approved : A.Giovannelli	
Date: Wednesday, November 15, 2000	Sheet 1	of 1

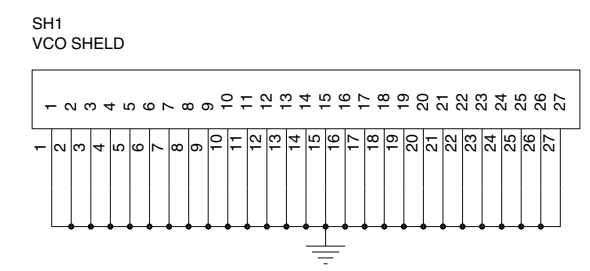
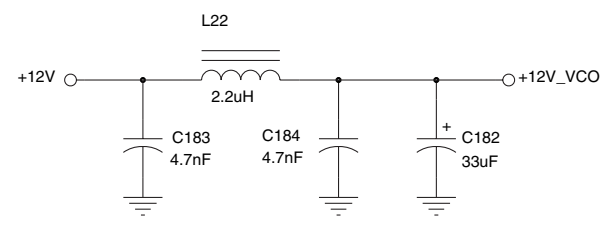
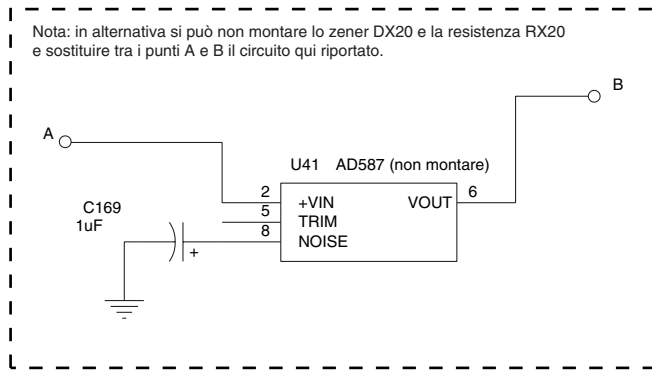
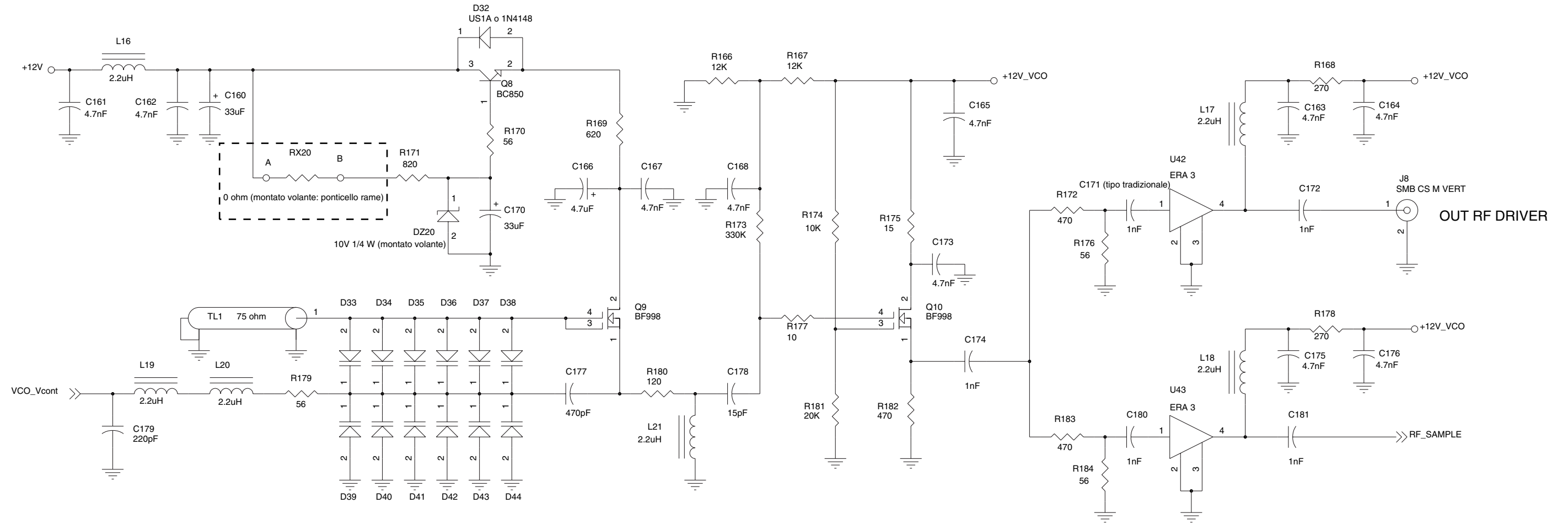

Via G.Amendola 9 44028 Poggio Renatico (FE) Italy Tel +39 0532 829965 Fax +39 0532 829177 Website WWW.ELENOS.COM		
Title: VCO		
Board Code: ETG500V1.1a	Model: ETG250/300	Rev 1.1
Proj. Engr. : A.Tomassini	Approved : A.Giovannelli	
Date: Wednesday, November 15, 2000	Sheet 1 of 5	

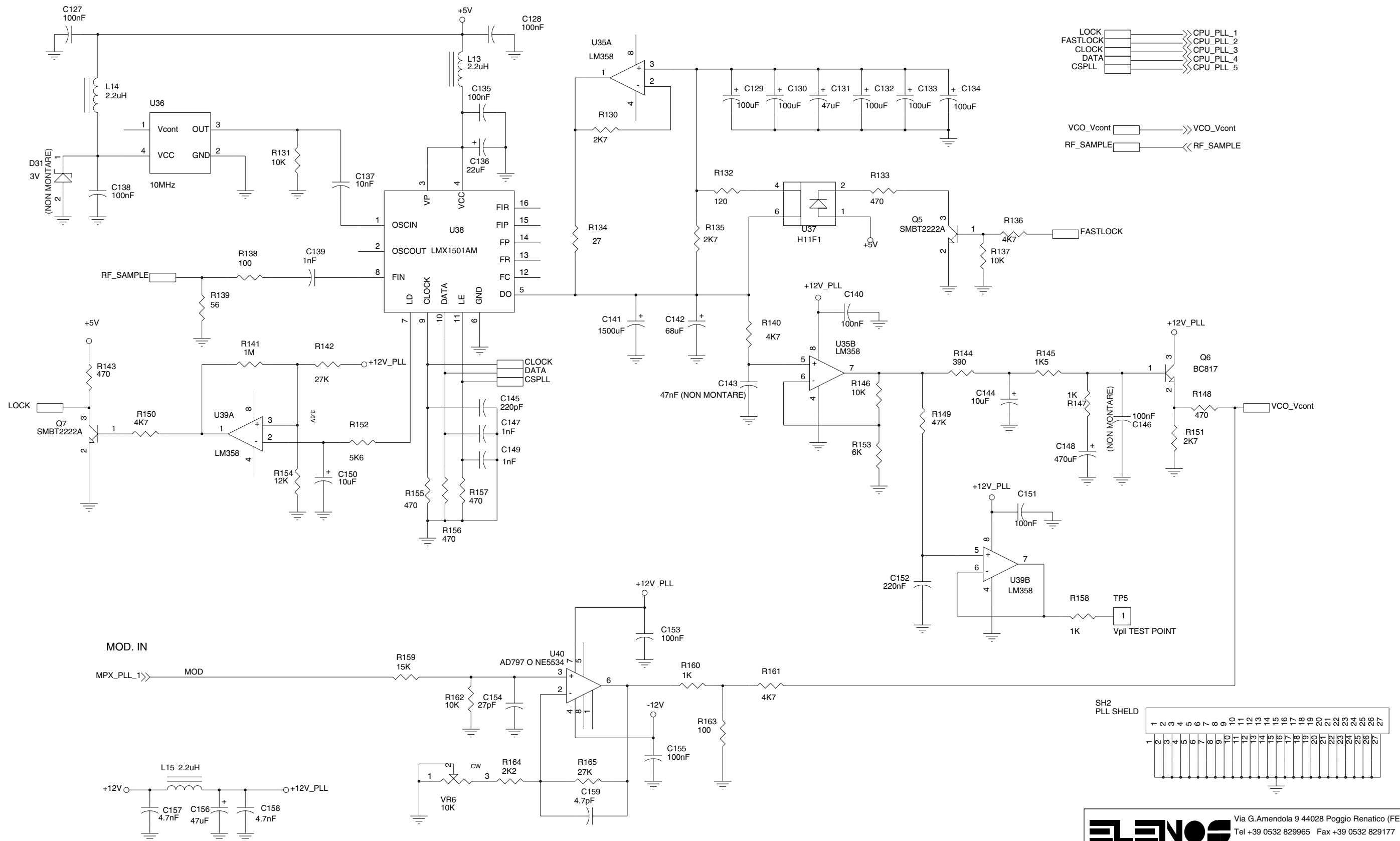

ELENOS Via G.Amendola 9 44028 Poggio Renatico (FE) Italy
Tel +39 0532 829965 Fax +39 0532 829177
Website WWW.ELENOS.COM

Title: PLL		
Board Code: ETG500V1.1a	Model: ETG250/300	Rev 1.1
Proj. Engr. : A.Tomassini	Approved : A.Giovanelli	
Date: Wednesday, November 15, 2000	Sheet 2	of 5

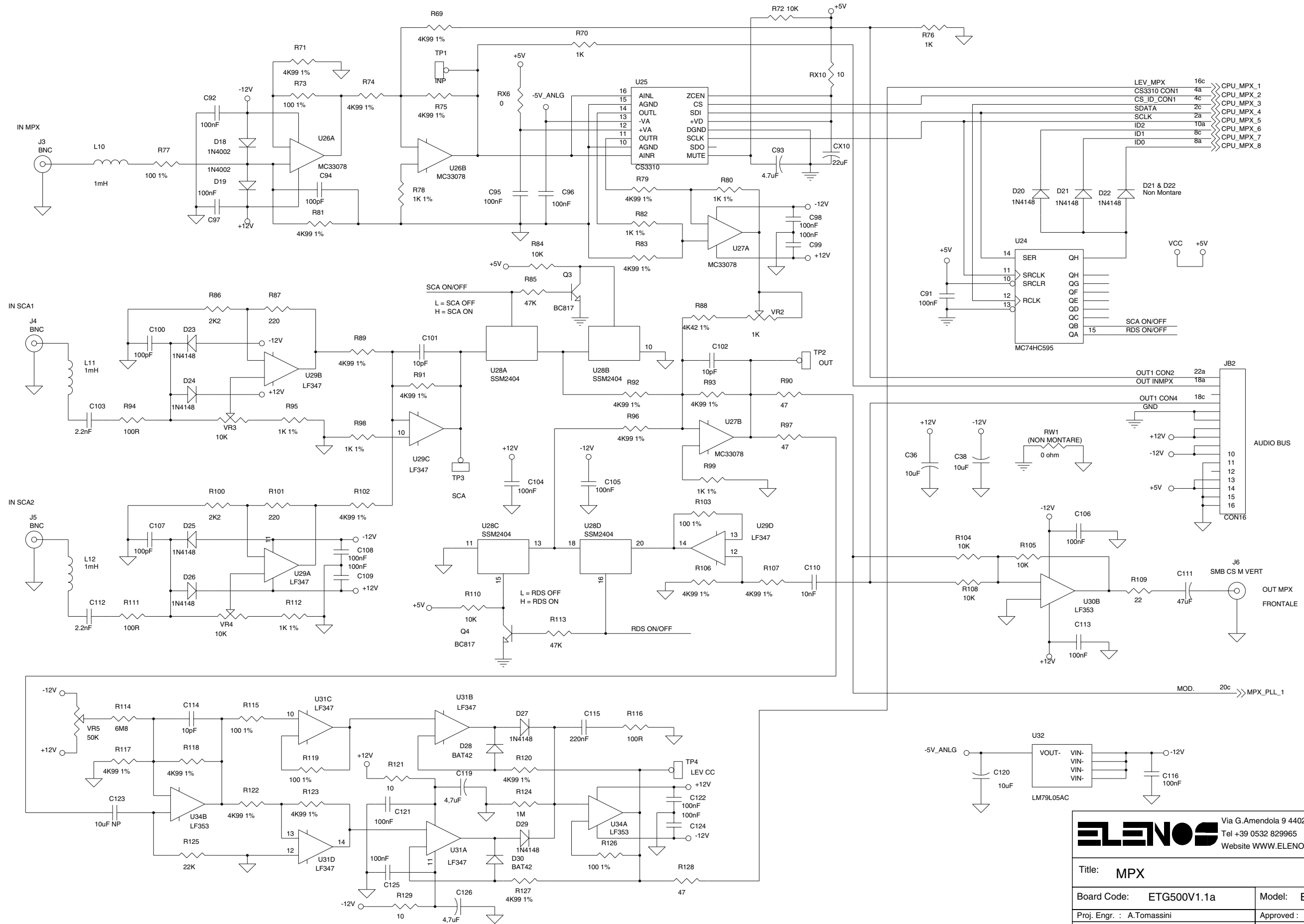

ELENOS Via G.Amendola 9 44028 Poggio Renatico (FE) Italy
Tel +39 0532 829965 Fax +39 0532 829177
Website WWW.ELENOS.COM

Title: MPX		
Board Code: ETG500V1.1a	Model: ETG250/300	Rev 1.1
Proj. Engr. : A.Tomassini	Approved : A.Giovannelli	
Date: Wednesday, November 15, 2000	Sheet 3	of 5

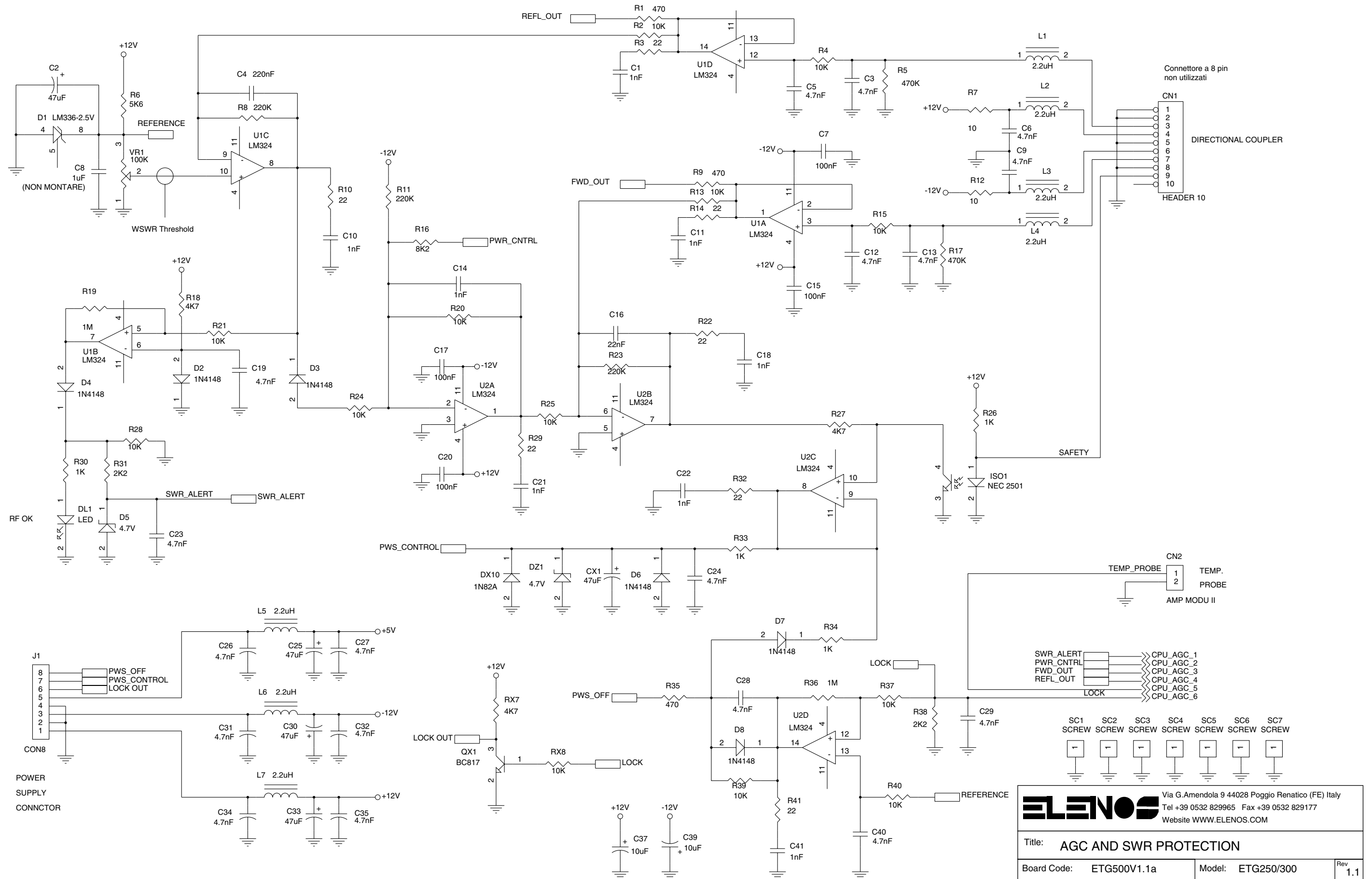

ELENOS Via G.Amendola 9 44028 Poggio Renatico (FE) Italy
Tel +39 0532 829965 Fax +39 0532 829177
Website WWW.ELENOS.COM

Title: **AGC AND SWR PROTECTION**

Board Code: ETG500V1.1a	Model: ETG250/300	Rev 1.1
Proj. Engr. : A.Tomassini	Approved : A.Giovannelli	
Date: Wednesday, November 15, 2000	Sheet 4 of 5	

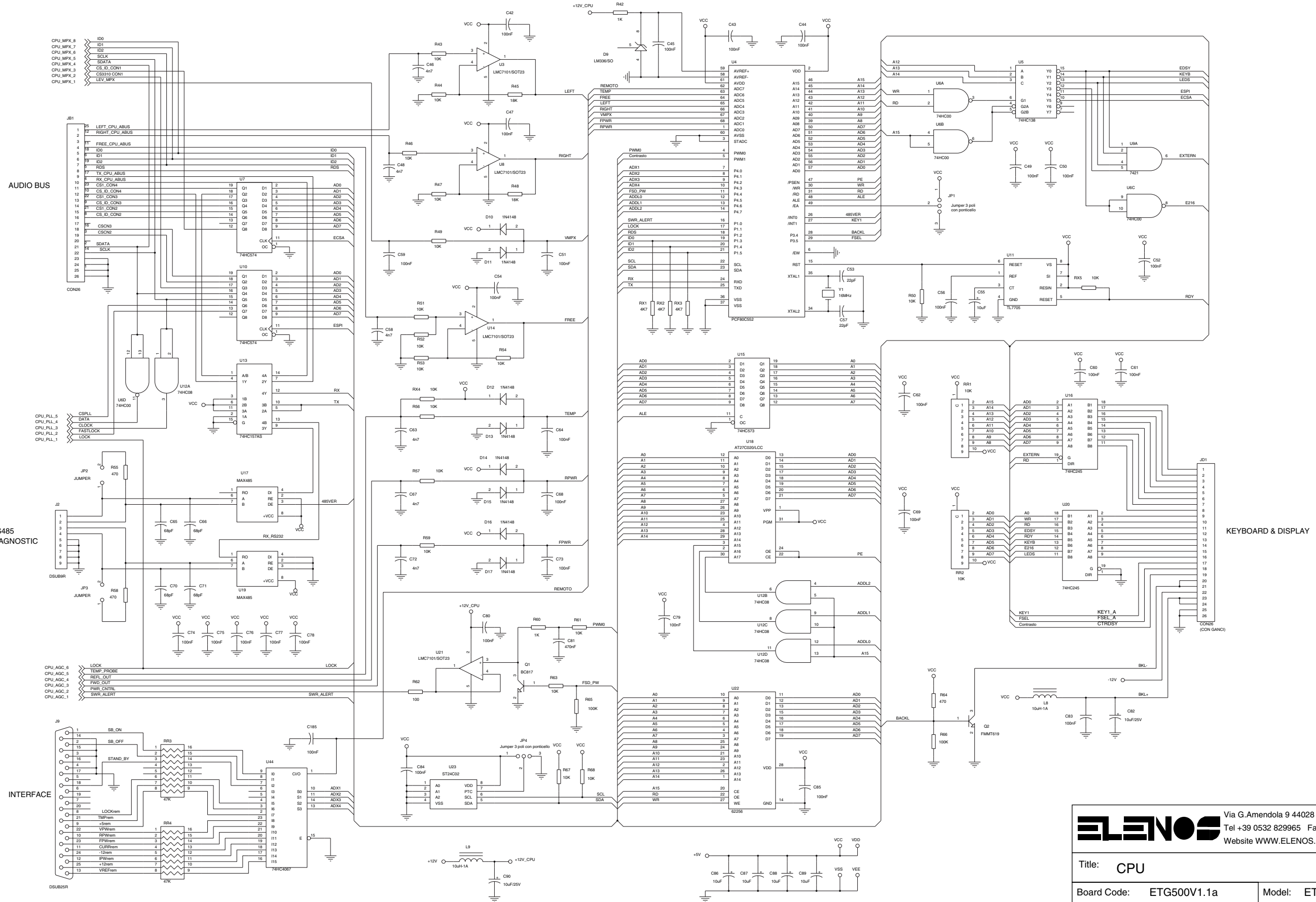

ELENOS Via G.Amendola 9 44028 Poggio Renatico (FE) Italy
Tel +39 0532 829965 Fax +39 0532 829177
Website WWW.ELENOS.COM

Title: CPU

Board Code: ETG500V1.1a	Model: ETG250/300	Rev 1.1
Proj. Engr. : A.Tomassini	Approved : A.Giovannelli	
Date: Wednesday, November 15, 2000	Sheet 5 of 5	

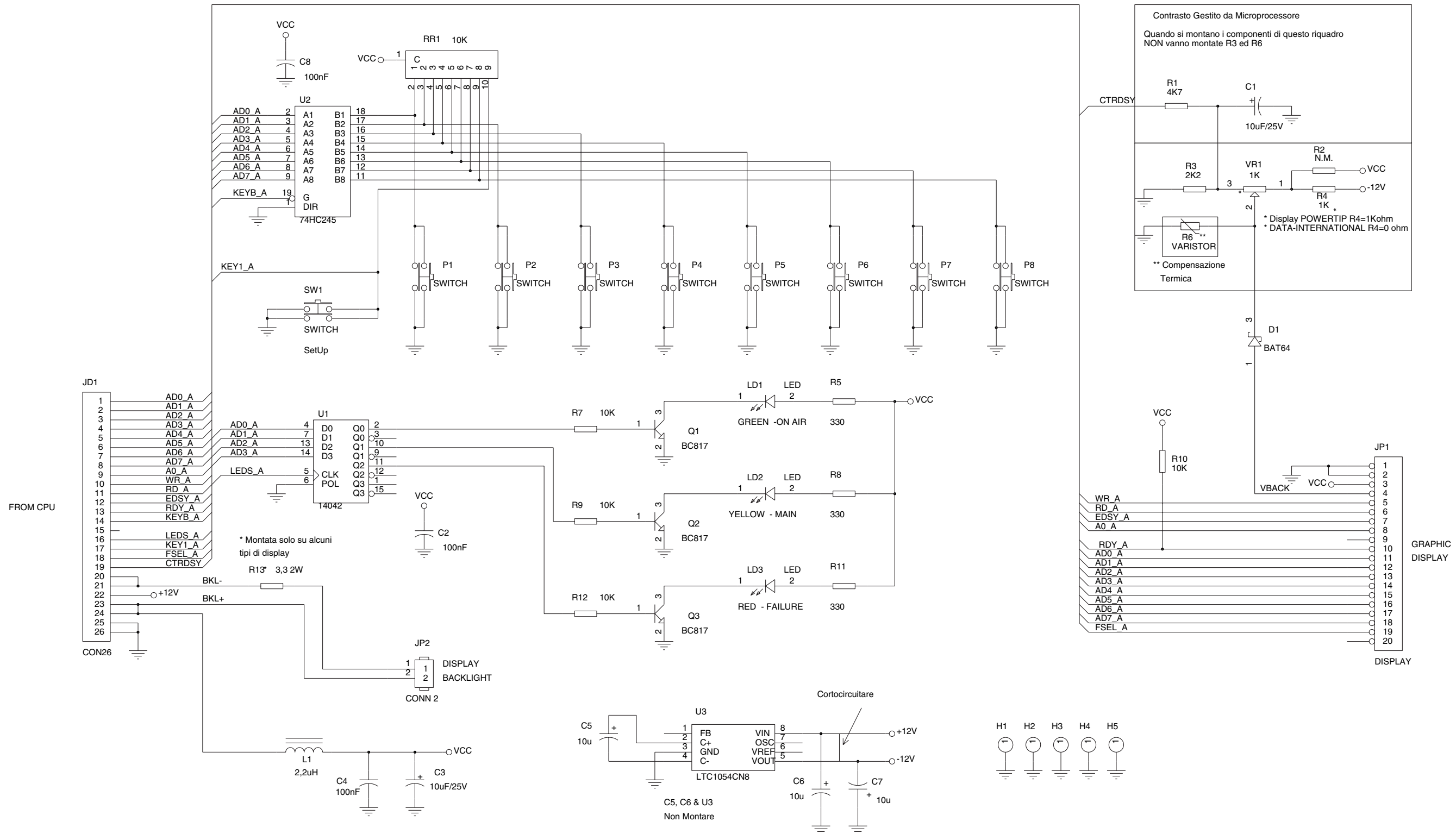

ELENOS Via G. Amendola 9 44028 Poggio Renatico (FE) Italy
Tel +39 0532 829965 Fax +39 0532 829177
Website WWW.ELENOS.COM

Title: **KEYBOARD**

Board Code: KEYB.ETG500V1.0A	Model: ETG250/300	Rev 1.1
Proj. Engr. : A.Tomassini	Approved : A.Giovannelli	
Date: Wednesday, November 15, 2000	Sheet 1	of 1