

# SF300

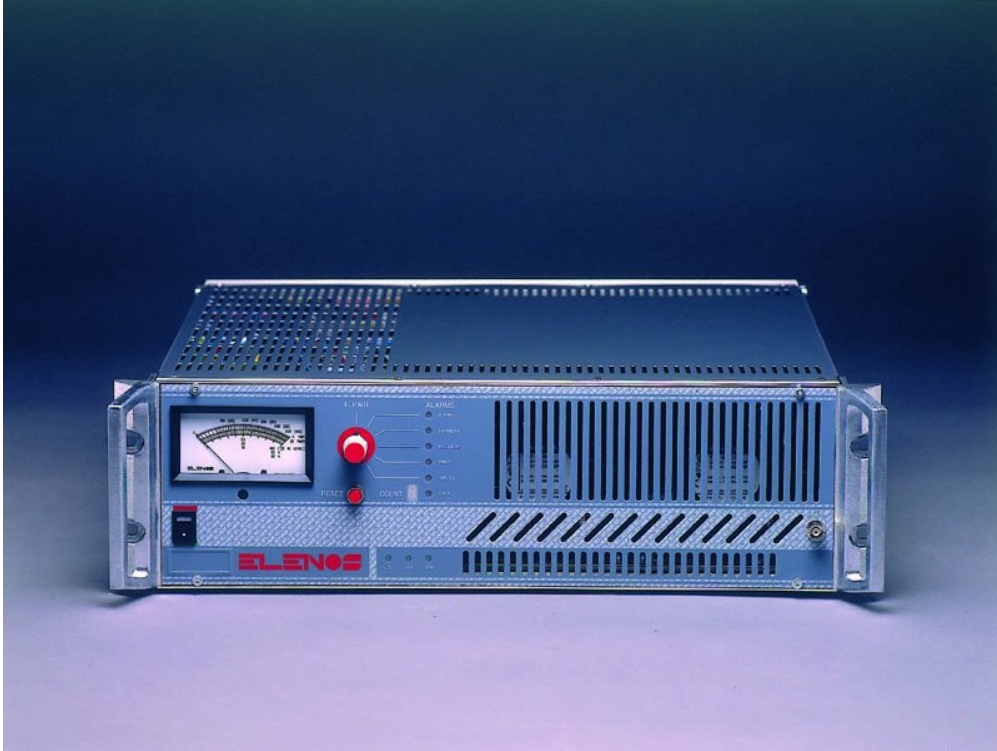

**ELENOS**

## BROADCAST EQUIPMENT

Via G. Amendola 9  
44028 Poggio Renatico  
Ferrara – Italy

Tel : +39 532 829 965

Fax : +39 532 829 177

E-mail: [info@elenos.com](mailto:info@elenos.com)

[support@elenos.com](mailto:support@elenos.com)

Web site: <http://www.elenos.com>

**The manufacturer reserves the right to change at any time this handbook without the condition to advise that the version has been updated.**

**2000 Elenos S.r.l.  
Printed in Italy  
Cod. MAN0011**

<p>21/10/1996 Preliminary mater in English 10/04/1997 Rev. 1 04/01/1998 Rev. 2</p>
--

## SUMMARY

<b>GENERAL DESCRIPTION</b> .....	4
<b>FRONT VIEW</b> .....	5
<b>TECHNICAL FEATURES</b> .....	7
<b>PRECAUTIONS</b> .....	8
<b>MANUFACTURER'S RECOMMENDATIONS</b> .....	9
<b>TECHNICAL DESCRIPTION</b> .....	10
<b>USER INTERFACE</b> .....	11
<b>REMOTE INTERFACE</b> .....	12
<b>INSTALLATION</b> .....	14
<b>FRONT PANEL DIAGNOSTICS</b> .....	16
<b>TROUBLESHOOTING</b> .....	19
<b>TOP VIEW</b> .....	21
<b>BOTTOM VIEW</b> .....	22
<b>R.F. BLOCK DIAGRAM</b> .....	23
<b>POWER SUPPLY AND MEASUREMENT BLOCK DIAGRAM</b> .....	24
<b>LAYOUT OF COMPONENTS</b> .....	26
ESPL02.1 (Splitter input Board).....	26
EF150FM.1 (Power Amplifier).....	28
LPF501FM (Low Pass Filter) .....	30
E20147 (Power Supply Board) .....	33
E30501.2N (Protection board) .....	39
E30502 (Front panel board) .....	44
E40101 (back board).....	47
E40500 (connection board).....	50
SF000070 - Thermal Probe .....	53
EPCB0200 (Clock Buffer Board) .....	54
EPCB0240 ( R.F.I. Protection Board).....	55
EPCB0239 (Watch-Dog Board).....	56

## GENERAL DESCRIPTION

The SF300 model is a solid state amplifier without variable tuning circuits for the 87.5 to 108 MHz frequency band, intended as a supplementary power stage for FM modulators. The unit is designed to operate as a final stage powering a radiating system, or as an intermediate stage in a chain of amplifiers, thus loaded by the input stage of a following amplifier. In both cases an exciter modulator is necessary.

FRONT VIEW

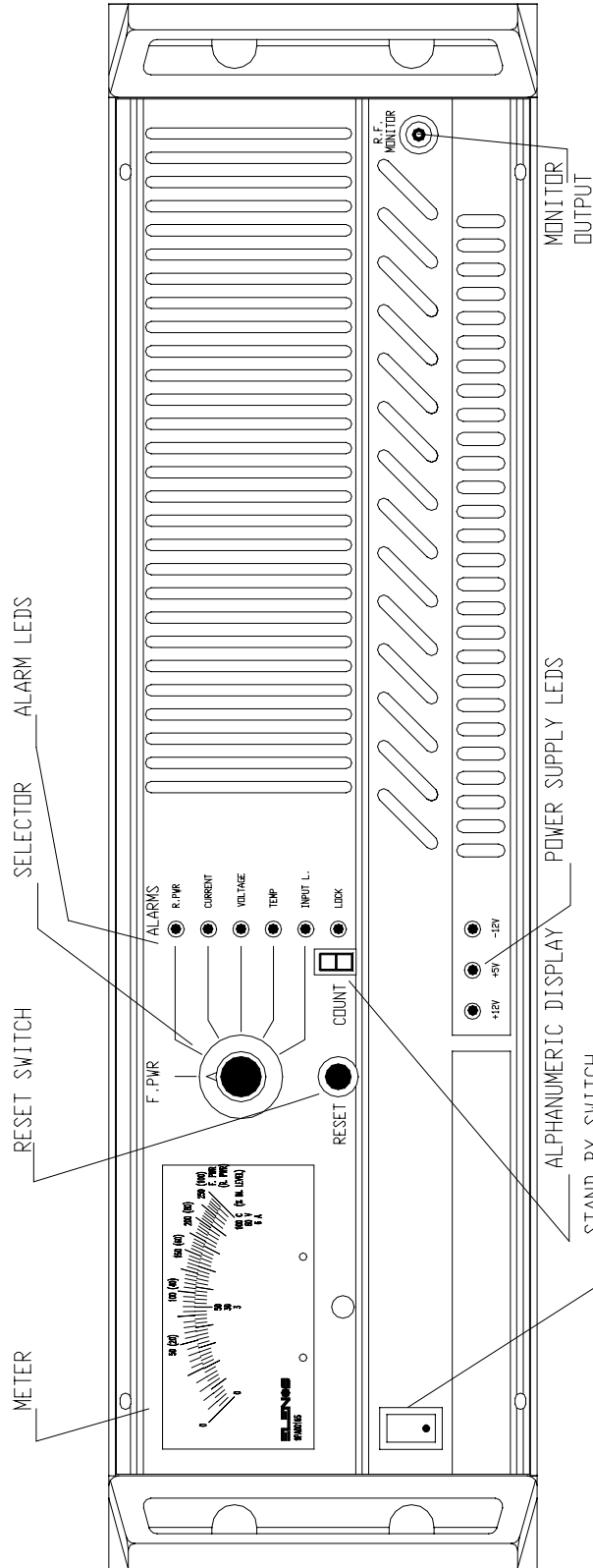

REAR VIEW

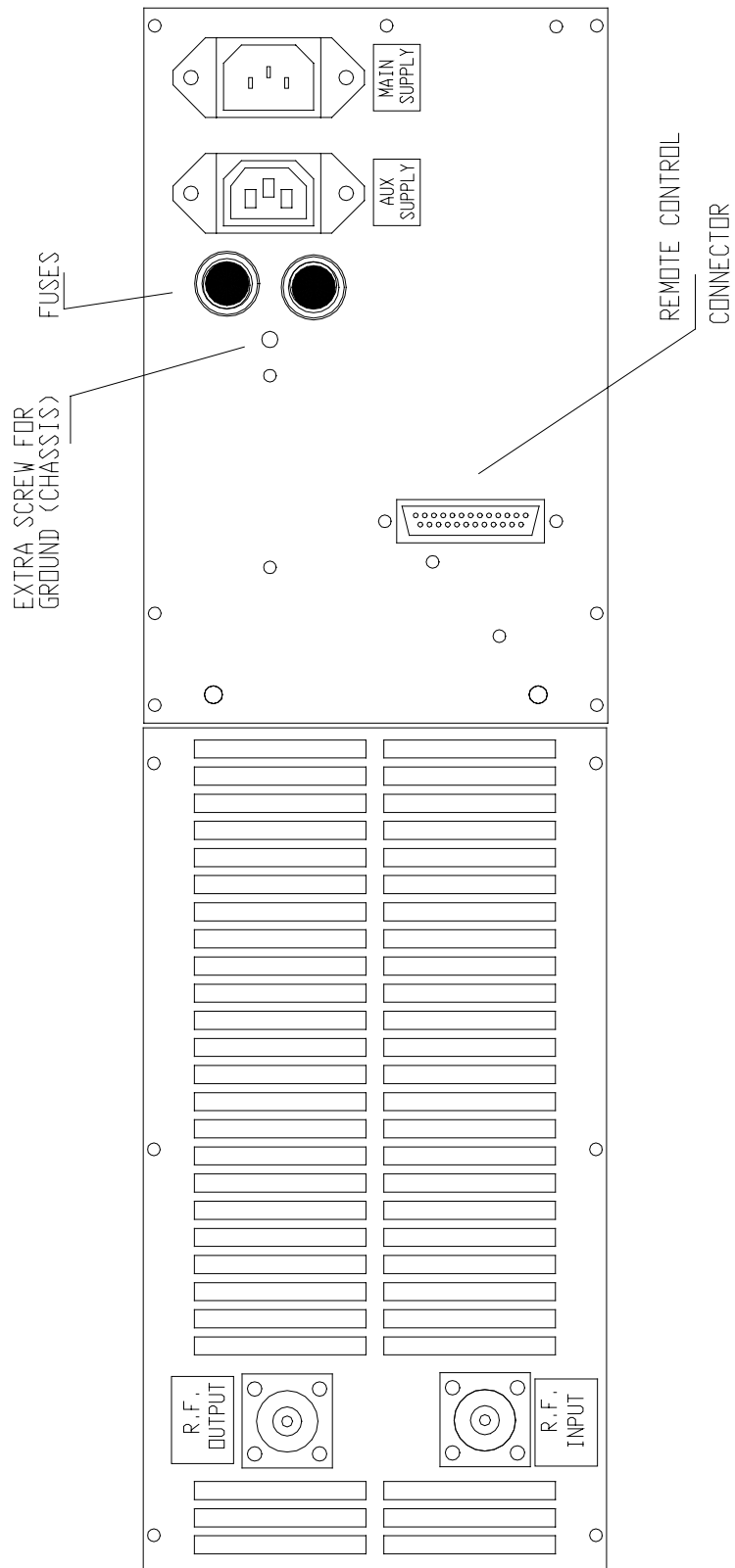

## TECHNICAL FEATURES

**Max. power output:** 300W

**Max. power for 300W output:** from 5W to 12W

**Mosfet efficiency at 300W output:** from 52% to 68%

**Mosfet voltage:** from 22V to 48V DC

**Mosfet rest current:** from 5mA to 25mA

**Mosfet current at 300W:** from 8A to 10A

**Input SWR:** less than 1.6W

**Differential of the heat-sink temperature at 300W out :** 35°C

**Supply voltage:** 208/220/240 V with mains voltage changeover to 110V

**Mains frequency:** from 47Hz to 70Hz

**Power supply for 150W output:** 900VA maximum

**Spurious emission at the antenna connector:** - 72dBc

**Ambient temperature:** from -5 to +45°C

**Relative ambient humidity:** up 95% (45°C) NOT CONDENSED

**Protection of output reflected power:** 40W max.

**Protection of Mosfet current:** 14A max.

**Protection of input power:** 40W max.

**Thermal protection:** 85°C max.

## PRECAUTIONS

**Do not handle the unit in any way unless all its protection panels are completely closed and it is connected to a good earth which can ground parasitic currents circulating in the chassis.**

**Do not operate the unit unless all its panels are completely closed.**

**Do not open the unit for internal inspection of any sort unless the line supply cable is disconnected from the supply and all other connections to other equipment are also disconnected.**

**Any operations which need to be carried out with panels open should be left exclusively to qualified personnel and those aware of all the risks associated with operating high voltage equipment generating significant RF power levels.**

**Some components used in the construction of the unit contain TOXIC SUBSTANCES. If, on a visual inspection, any components reveal themselves to be damaged, fractured or incomplete, proceed with extreme caution to avoid contact with the hands or any other part of the body. The principal components of the unit operating at radio frequency contain the highly dangerous substance, Beryllium Oxide.**

### **WARNING! BERYLLIUM OXIDE IS LETHAL**

**Only qualified, competent personnel are capable of handling the equipment and its electronic components without risk. Owners equipment are obliged to conform with these recommendations.**



## MANUFACTURER'S RECOMMENDATIONS

The installation of any electronic apparatus exposes personnel to risk; ELENOS explicitly requests that no work is carried out unless at least two people are present. This is in view of the fact that over and above the electrical connections that are necessary, the sheer physical weight of the unit will not allow a single person to install the unit with complete safety. Do not commence any operation before reading all safety and operational instructions. ELENOS advises the following safeguards: hang a poster in the equipment room with clear instructions for first aid in the event of personal injury; provide local first aid equipment and facilities and display telephone numbers and means of contacting local public or private emergency services which can easily be referred to by all personnel.

## TECHNICAL DESCRIPTION

The SF300 is a solid state amplifier using MOSFET power devices as the active radio frequency element. The equipment comprises 2 RF amplifier modules (card EF150FM1) which are matched for input/output impedance of  $50\Omega$ , an input divider circuit (card ESPL06) and a low-pass filter (card LPF501FM) which is also a low-pass filter and an output power measurement circuit. The equipment features a sophisticated array of supervisory circuits which monitor the operation of the RF circuits so as to maximise operational life and minimise down-time and operator intervention. The RF modules' power supply circuit (card E20147) employs phase-angle switching rectification. The line transformer is of toroidal construction with an electrostatic screen separating the primary and secondary windings. The rectifier's filter is inductive and capacitive. Control of the stabilised voltage is by a microcontroller which controls the output voltage as a function of the RF power being developed. The microcontroller on the power supply card (one of three) also monitors the safety of the RF power modules; in the event of parameters going outside their limits, it will reduce the voltage supplied to the modules and thus the total RF power. The power supply is protected against accidental short circuits and, importantly, features a rapid power shut-down system (reaction time about  $200\mu\text{s}$ ) which can save the delicate MOSFET devices from damage which they would otherwise incur even after short periods of overload. The master card (card E30501) controls the power-up sequence and any reset required after a fault has triggered a protection mechanism of any sort. The program of the microcontroller may be partially customised at the customer's request to adapt it to local operating requirements. This card is in continual digital communication with the power supply card and the front panel card (card E30502). It collates information received from the power supply and the operator and can supply current or past data to the operator via codes displayed on the front panel. It also routes commands to the power supply received from the front panel or from the remote connector situated on the remote interface card (card E40101).

## USER INTERFACE

All the controls and indications of the status of the unit needed by the operator are situated on the front panel. The unit does not have a power on/off switch but rather a STAND BY switch. This switch is situated on the lower left of the panel; in position ( • ) the equipment is operational, otherwise operation is suspended, i.e. power is no longer supplied to the RF amplifier stages and the auxiliary line output for an external modulator is disabled. In the front panel also features a meter which can display alternatively: power output (F. PWR), reflected power (R. PWR), current drawn by the RF amplifier stages (CURRENT), amplifier stage supply voltage (VOLTAGE) and input power from the exciter (INPUT L.). Other indicators with the same names display the normal or abnormal, current or past operating status of the apparatus. The LOCK indicator lights when a temporary or permanent shut-down of the unit has occurred as a result of either operator intervention or a fault. An alphanumeric display (COUNT) is situated on the front panel together with a selector. The selector selects the parameter to be shown on the meter and also influences the alphanumeric display. When the unit has been functioning normally, the alphanumeric display shows a 0 (except in the case of F. PWR and VOLTAGE). Otherwise the number of faults pertaining to the parameter selected is displayed. If, in the past, an anomaly occurred, the corresponding indicator remains permanently lit. These indicators can light intermittently during Automatic Power Control intervention. If an operational parameter being monitored, has exceeded the alarm threshold, the RF modules' power supply will reduce the supply voltage and therefore the power dissipated, in an attempt to avoid a complete shut-down with the consequential loss of service, on the basis that: better less power output than no power output. When the selector is in the F. PWR position, the function is special: the alphanumeric display will show S if the unit is in stand-by and P if it is operational. When VOLTAGE is selected, the alphanumeric display will show a sequence of 2 consecutive characters, an error code useful as a diagnostic (see table of error codes) or a confirmation of normal operation. Not all faults generating error codes are permanent, the temporary removal of electrical power from the apparatus leaves two possibilities: remove the cause of the shut-down or repair the equipment. Clearly, faults due to failure of the microcontrollers cannot be ruled out and these will preclude any diagnostic assistance. Shut-downs (LOCK indicator lit) are of two types: permanent, without any attempt to reset, and temporary shut-down with successive attempts at automatic reset. The period between resets have been programmed according to the type of fault. The equipment will attempt resets for 24 hours without operator intervention, unless the fault is considered non-resettable. The RESET button can be used by the operator when the equipment has shutdown due to a fault which is no longer believed to be a cause of malfunction. This will clear the memory of previous faults but has no effect if the fault has been identified as fatal. Three indicator lights for other internal voltages are situated in the lower central part of the panel; these should be lit whenever the unit is powered from the line supply. The R.F. MONITOR socket provides a sample of the power output of the unit, attenuated by 40-50 dB, for connection to a spectrum analyser and can be used to check correct operation of the apparatus and any anomalies present in the radio spectrum.

## REMOTE INTERFACE

At the rear of the unit, a CANNON DB25F connector is situated, labelled REMOTE. This connector allows remote devices to control various operational parameters of the unit and to activate various operations even via automatic controllers such as timers, interlocks and other similar electronic or electromechanical devices.

Pin description:

**Pin #1** (remote STAND BY 1). Can be used in conjunction with pin #14 to reset after an enforced shut-down. The unit will leave the STAND BY state when pin #1 and pin #14 are connected for a short period.

**Pin #2** (remote STAND BY 2). Can be used in conjunction with pin #14 to enforce a shut-down. The unit will enter STAND BY mode when pin #2 and pin #14 are connected together for a short period.

**Pin #3**, pin #4, pin #5, pin #15, pin #16, pin #17, (GND.) are connected to the units chassis and may be used as analog signal returns when connecting to external equipment.

**Pin #6** RESERVED

**Pin #7** (S.C.L.). One of two serial communication lines; IIC BUS, clock signal

**Pin #8** (LOCK). If low (0V), the unit is operational, if high (12 Volts), the unit has shut-down.

**Pin #9** (5 Volts). Internal 5V supply indicator.

**Pin #10** (R. PWR). Reflected power signal normalised at 2 Volts f.s.d. on the front panel meter.

**Pin #11** (CURRENT). Signal representing current drawn by the RF stages, normalised at 2 Volts f.s.d. on the front panel meter.

**Pin #12** (INPUT L.). Signal representing RF exciter input voltage, normalised at 2 Volts f.s.d. on the front panel meter.

**Pin #13** (V. REF.). Voltage normalised for the front panel meter (2 Volts).

**Pin #14** (STAND BY COMMON) see pin #1 and pin #2.

**Pin #18** (STAND BY SWITCH). When connected to GND via an external switch, the unit is forced in stand by mode.

**Pin #19** (S.D.A.) One of two serial communication lines; IIC BUS, data signal.

**Pin #20** RESERVED

**Pin #21** (TEMP.). Signal representing heatsink temperature, normalised at 2 Volts f.s.d. on front panel meter.

**Pin #22** (VOLTAGE). Signal representing RF module power supply voltage, normalised at 2 Volts f.s.d. on front panel meter.

**Pin #23** (F. PWR.). Signal representing the units RF power output, normalised at 2 Volts f.s.d. on front panel meter.

**Pin #24** (-12V). Internal -12V voltage indicator.

**Pin #25** (+12V). Internal +12V voltage indicator.

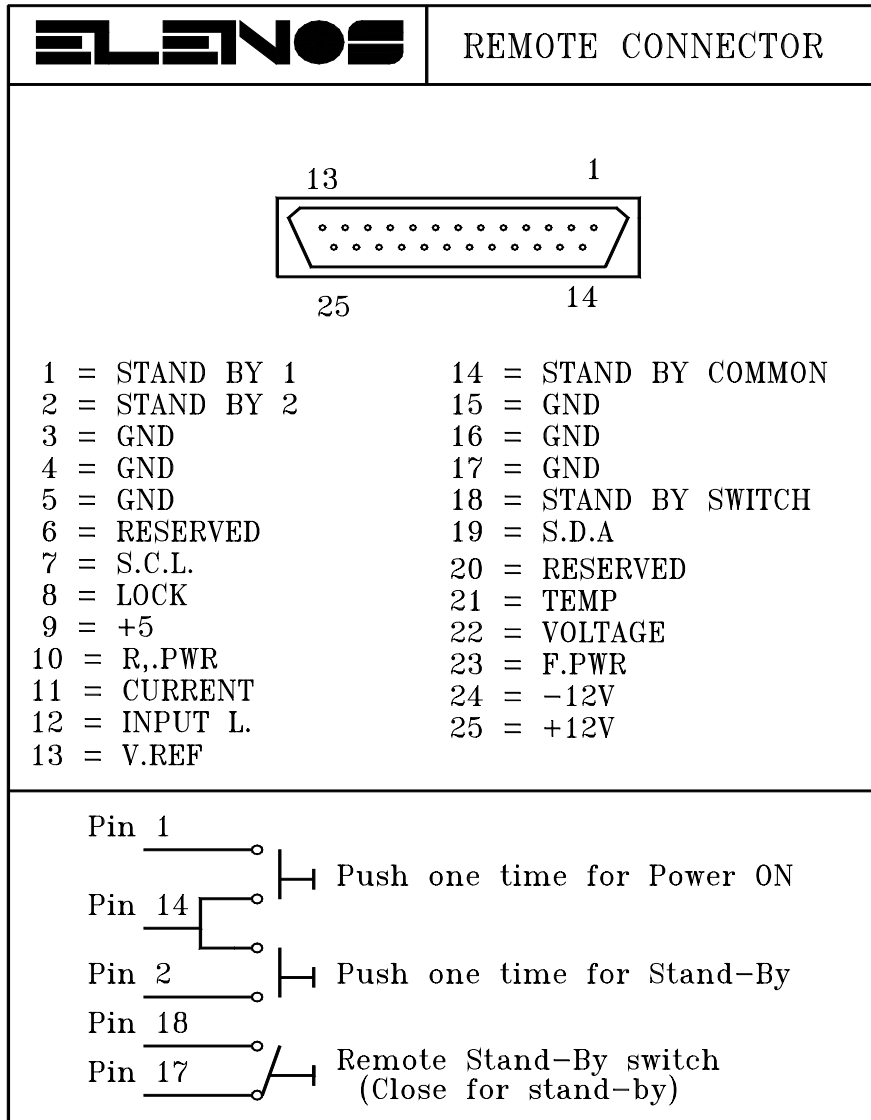

## INSTALLATION

The following is an important pre-requisite to operation: the installation site must conform to necessary safety standards for equipment and personnel. In particular, the power supply should feature a cut-out facility in the event of over-current; safety breakers for protecting personnel and earth connections for all equipment. The installation site should have outlets for the discharge of hot air produced by the equipment and a supply of fresh air. The equipment must operate within an ambient temperature range of -5 to 45°C and at relative humidities of less than 95% (non-condensing). The SF300 is not a transmitter but an amplifier which requires at least a modulator, if not additional power stages. This poses the problem of integrating a system with other technical specifications which must comply with the transmission regulations of the country of installation. It is therefore necessary to consult this technical manual and especially the chapter regarding problems of transmitter systems which are assembled from diverse components. Two configurations of the SF300 are envisaged:

- 1) as the final amplifier driving the radiating system.
- 2) as an intermediate amplifier driving the input stages of another amplifier.

In both cases, the equipment will leave ELENOS laboratories without any special setup. Before installation, all packing pieces used during transit should be removed from the equipment. Then a visual inspection should be made of the equipment to ensure that no damage has been incurred during transport. In the case of any evident damage, contact ELENOS, for return under warranty. All the technical manuals supplied with each unit which make up the system being installed should be read to ensure that the conditions of guarantee are complied with and, most importantly, that any danger to personnel is avoided. Check that the line voltage stated on the test documents corresponds with that of the local supply, if not, connect an appropriate means of conversion. Situate the SF300 and its modulator in their final position. The modulator must be of a quality commensurate with the service required (mono/stereo) and of variable power output from the lowest power possible upto at least 17W. The connections between the SF300 and its modulator must be as follows: the modulator must receive its line supply from the AUX SUPPLY socket on the rear of the SF300. In turn the SF300 receives its line supply from a successive amplifier, if present, or direct from the electricity supply (see the technical manuals of other stages connected to the SF300 for more information). The radio frequency connections start at the modulator, the output of which should be connected to the R.F. INPUT socket of the SF300. The R.F. OUTPUT connector of the SF300 should be connected to the antenna or successive amplifying stages. The modulator features a regulator to adjust the RF power output, this should be set so that, at switch-on, output power is at a minimum (see the modulator technical manual for more information regarding adjustment and connection to other equipment). On the rear of the unit, a supplementary earth connection can be made via the exposed captive screw. This allows a low-resistance path to earth for atmospheric electrostatic discharges and may also be used for special connection configurations. When all the equipment is connected and all panels are

closed, the units can be switched on in the following sequence: first the final stage the whole transmitter system, then the intermediate stages and finally the modulator. If the system is configured with the SF300 as the final stage, the modulator should be adjusted to regulate the output power of the SF300 amplifier to comply with the terms of the homologation licence for the site in question. It will clearly be necessary to test not only the correct operation of the system but also compliance of parameters with transmission regulations. If the SF300 is instead an intermediate stage of a more complex transmitter, the calibration instructions regarding the final stage should be referred to, ensuring that the SF300 is not exposed to risk of damage by other devices in the system. The SF300 amplifier has no adjustment for tuning or other parameters; from a functional point of view it is passive. Its characteristics are determined by equipment up- and down-stream of it. The operator using the SF300 is therefore only concerned with ensuring that the limits of safe operation are not exceeded indefinitely: the modulator must not exceed the tolerated level of excitation power, including situations in which ambient factors downgrade performance; for successive stages the operator must perform the calibration of input stages to ensure safe levels of reflected power displayed by the SF300's meter. For safety limits on all operational parameters, see the table of typical and maximum specifications. The SF300 features internal circuits which automatically reduce the output power if other parameters go outside the limits of safety. The operator responsible for calibration may exceed some of the limits temporarily, but must not leave the site with the unit indicating Automatic Power Control (flashing lights on the front panel). In this case the stability of the RF output power is not guaranteed (see the chapters entitled TECHNICAL DESCRIPTION and USER INTERFACE of the SF300 manual). Consult the table of typical operating parameters and their safety limits for the SF300 and other connected equipment to ensure that the installation operations are complete.

## FRONT PANEL DIAGNOSTICS

### A) Diagnostic with selector in VOLTAGE position

When the selector is in the VOLTAGE position, it is possible to obtain useful diagnostic data from the COUNT alphanumeric display. This display shows a 2 character code which identifies the functional status of the unit. Anomalies can be permanent or temporary. The error code disappears if the amplifier returns to normal working. The code will remain displayed permanently if the fault remains indefinitely. Each message has a technical and logical significance and timing which is described below:

**A0:** Appears when there are communication difficulties between cards E30501 and E20147.4. The status of other indicators is irrelevant and the equipment will not function. Check the integrity of connections between the two electronic cards and the efficiency of the screen which protects against RF interference. A permanent fault on one of the automatic control cards is also possible.

**A1:** This code appears when the supply current drawn by the RF modules is excessive. In this case the (CURRENT) and (VOLTAGE) indicator will also be lit. For each occurrence of this alarm condition, the amplifier will shut down for 7 seconds and will then attempt an automatic reset. If 9 of these events occur consecutively, the unit will shut down for 9 seconds, clear the event counter (CURRENT) and again attempt an automatic reset. If, instead, this message appears only once, the fault is not permanent and is considered as an isolated incident and consequently ignored by the protection logic. Check the power transistors of the series regulator and for short circuits caused by foreign bodies.

If this message has appeared just once it is not a permanent fault but a single event which is then ignored by the protection logic. Check the integrity of the EF150FM1 module; if a module is not functioning, it is possible that excess current will be drawn. Check the output and low-pass filter connections.

**A2:** This code appears when there is a short circuit between input and output of the series regulator on the E20147.4 power supply card. The RF module power supply is not functioning correctly. For each intervention of this type, the amplifier will shut down for 7 seconds before trying again. If 2 of these events occur consecutively, the amplifier will shut down for 9 seconds, clear the event counter (CURRENT) and again attempt an automatic reset. The LOCK and VOLTAGE indicator will also appear on the front panel. If, instead, this message appears only once, the fault is not permanent and is considered as an isolated incident and consequently ignored by the protection logic. Check the power transistors of the series regulator and for short circuits caused by foreign bodies.

**A3:** This code appears when current consumption becomes excessive but there is no input voltage on the power supply card E20147.4. For each occurrence of this type, the amplifier will shut down for 7 seconds before trying again. If 2 of these events occur consecutively, the amplifier will shut



down for 9 seconds clear the event counter (CURRENT) and again attempt an automatic reset. The LOCK and VOLTAGE indicator will also appear on the front panel. If, instead, this message appears only once, the fault is not permanent and is considered as an isolated incident and consequently ignored by the protection logic. Check for short circuits between the power supply card input and the chassis. Quite common in this instance is the breakdown of the thermal insulator of one of the series regulator power transistors.

**A4:** This code appears when current consumption is high but there is no power output. For each occurrence of this type, the amplifier will shut down for 7 seconds before trying again. If 2 of these events occur consecutively, the amplifier will shut down for 9 seconds clear the event counter (CURRENT) and again attempt an automatic reset. The LOCK and CURRENT indicator will also appear on the front panel. If, instead, this message appears only once, the fault is not permanent and is considered as an isolated incident and consequently ignored by the protection logic. Check that the RF power modules are functioning.

**A5:** This code appears when there are problems with the RF output of the amplifier, in particular when there are sporadic variations in output power. In this case the R. PWR indicator will be illuminated. For each occurrence of this alarm condition, the amplifier will shut down for 7 seconds and will then attempt an automatic reset. If 9 of these events occur consecutively, the unit will shut down for 9 seconds clear the event counter (CURRENT) and again attempt an automatic reset. There are many causes of this alarm condition which can be complex: check that there is no RF self-oscillation; check for instability of excitation due to poor connections or modulator faults. If the modulator is a frequency conversion type, intervention of the squelch function of the radio link receiver can cause problems.

**A6:** This code appears when there are problems with the RF output of the amplifier, in particular when there is a sporadic or persistent mismatch with the radiating system or successive amplifying stage. In this case the R. PWR indicator will be illuminated. For each occurrence of this alarm condition, the amplifier will shut down for 7 seconds and will then attempt an automatic reset. If 2 of these events occur consecutively, the unit will shut down for 9 seconds, clear the event counter (R. PWR) and again attempt an automatic reset. Check if the amplifier's RF load is abnormal and for any intermittent faults. When the amplifier is driving a thermionic tube stage, this alarm condition can arise during the tuning phase of the input or when the tube is either very new or near the end of its life.

**A7:** This code appears when there are thermal problems with the amplifier, in particular excessive heating of the heatsink on which the RF modules and power supply are mounted. In this case the TEMP indicator will illuminate. For each occurrence of this alarm condition, the amplifier will shut down for 7 seconds and will then attempt an automatic reset. If 9 of these events occur consecutively, the unit will shut down for 9 seconds then, clear the event counter (TEMP) and again attempt an automatic reset. If, instead, this message appears only once, the fault is not

permanent and is considered as an isolated incident and consequently ignored by the protection logic. Check if the ambient temperature is occasionally exceeding specified values. Check if the flow of cooling air is working effectively. Check that the amplifier's internal cooling fan is functioning normally. Check the output of the amplifier; if the RF load is abnormal, overheating can occur.

**A8:** Message reserved.

**A9:** This does not indicate an anomaly. This code appears when the amplifier is in STAND BY mode as a result of operator intervention or control by other equipment. The LOCK indicator will also be lit.

**AA:** This does not indicate an anomaly. This code confirms that the equipment is fully functional, regardless of status of other front panel indicators. The code remains displayed even when the unit is in Automatic Power Control mode.

**AB:** This code appears when an RF input signal is present but the amplifier is disabled. Check that the modulator is connected to the AUX SUPPLY connector situated at the rear of the unit.

**AC:** This code appears when no voltage is present at the input of the power supply card. For each occurrence of this type, the amplifier will shut down for 7 seconds before trying again. If 2 of these events occur consecutively, the amplifier will shut down for 9 seconds then, clear the event counter and again attempt an automatic reset. The LOCK indicator will also appear on the front panel. Check the input circuits of the power supply card; the most likely cause is a short circuit.

**AD:** This code indicates that the 'syncro' circuit of the power supply card is not synchronising with line frequency; the unit is faulty. In this case the LOCK indicator will also be lit. Check the relevant parts of the E20147.4 card.

**AE:** Message reserved

**AF:** Message reserved

**Note:** During the initial phase of powering the unit, it is normal for all indicators to briefly light. If, when this sequence has finished, the segments of the alphanumeric display light in a rotating sequence, the unit is faulty. The problem should be sought in the digital connections between all the microcontroller cards.

#### **B) Diagnostic with the rotary selector in the PWR position.**

When the rotary selector is in the F PWR position, the fault count is not displayed and excess power protection is not expected. The following status codes appear on the alphanumeric display:

**S:** indicates that the amplifier is in STAND BY mode as a result of operator intervention or control by external equipment.

**P:** Indicates that the unit is ready to generate RF power.

**L:** Indicates faulty connection or operating sequence. Confirmed by the Ab message.

## TROUBLESHOOTING

**(1) The equipment cannot develop nominal output power.**

Check the front panel for an intermittent indicator light, this signifies that the equipment is operating automatically at reduced power level due to the corresponding parameter having exceeded its safe operating level. The only solution is to remove the electrical or ambient cause of the malfunction. Check that the output connections are correct - this is one of the most frequent causes of problems. Low output power can manifest even if the reading of the power output indicator is correct. The power supply regulates the voltage supplied to the RF modules as a function of the internal output power measurement; if the power does not rise, it is because the voltage is not increasing and it will be impossible to achieve maximum performance. In this case it will be necessary to either recalibrate the measurement of RF output power or to repair the circuits in question (consult ELENOS for necessary assistance). The reduced power output can be caused by a fault in one of the RF amplifier modules, or, less frequently, in other parts.

**(2) The unit does not develop power and immediately enters R. PWR protection or, at random, CURRENT protection, as soon as the input is excited.**

Check the RF output connections; it is likely that one or more of the radiating system connections is defective or operating inefficiently. A second important cause of this malfunction is the quality of the RF load which is connected to the output of the unit. If a narrow-band filter is connected, it is possible that some instability can arise leading to oscillations in some of the internal RF modules. If the filter is well connected and of high quality, this phenomenon is rare, nevertheless sporadic anomalies can occur. The solution in this case is to experiment: modify the length of the RF cables which connect the unit to the output filter and recalibrate the narrow-band output filter, attempting to better match the load which the filter presents to the amplifier. The loss of performance in the previous cases is the price that is paid for the wide-band characteristics of the tuning circuits. Check the behaviour of the modulator when RF power is developed; if the excitation of the SF300 is intermittent, the transmission spectrum becomes that of a pulse transmitter, not an FM transmitter. In this case it is likely that protection against a load mismatch, due to an excessively wide spectrum, is active and the only remedy is to eliminate the defect of the preceding modulator.

**(3) Output power is unstable**

Check the front panel for flashing indicators; the instability is due to reduced operating power by the internal protection circuits which avoid indefinite power reduction but do not guarantee stability. Remove the cause of the Automatic Power Control intervention by checking ambient factors or connections to other equipment as indicated, guided by the parameter indicated on the front panel. Furthermore check that the instability is not being generated by the modulator but being reflected by the SF300. Even successive stages can cause power instability; this can occur if

the load presented to the unit is unstable or there is a high content of harmonic or spurious radio frequencies. Check the harmonic and out-of-band content of the RF present between the SF300 and successive equipment.

**(4) The SF300 unit sporadically interrupts operation (even at reduced power) indicating R. PWR and CURRENT faults on the front panel.**

Check that the connectors of the radiating system and the successive stage are not defective or damaged. Check that the modulator is not generating instability with sudden power fluctuations or even large swings of carrier frequency. Check that the modulation frequency deviation is not excessive or that the frequency synthesizer is not losing control. Check the bandwidth of any selective filter attached to the output of the unit; if the frequency deviation is greater than the calibration, the transmitter cannot function properly. Check that the receiver of the radio link does not destabilise the modulator during squelch intervention. Check that overvoltage of the line supply is not destabilising the modulator frequency control. Many difficult problems can be resolved with low-cost solutions: connection of an input filter to the SF300 with the same transfer function as the output filter; supply of the modulator and SF300 via mains-borne interference filters; supply of equipment via stabilisers with reserves of power capacity.

### TOP VIEW

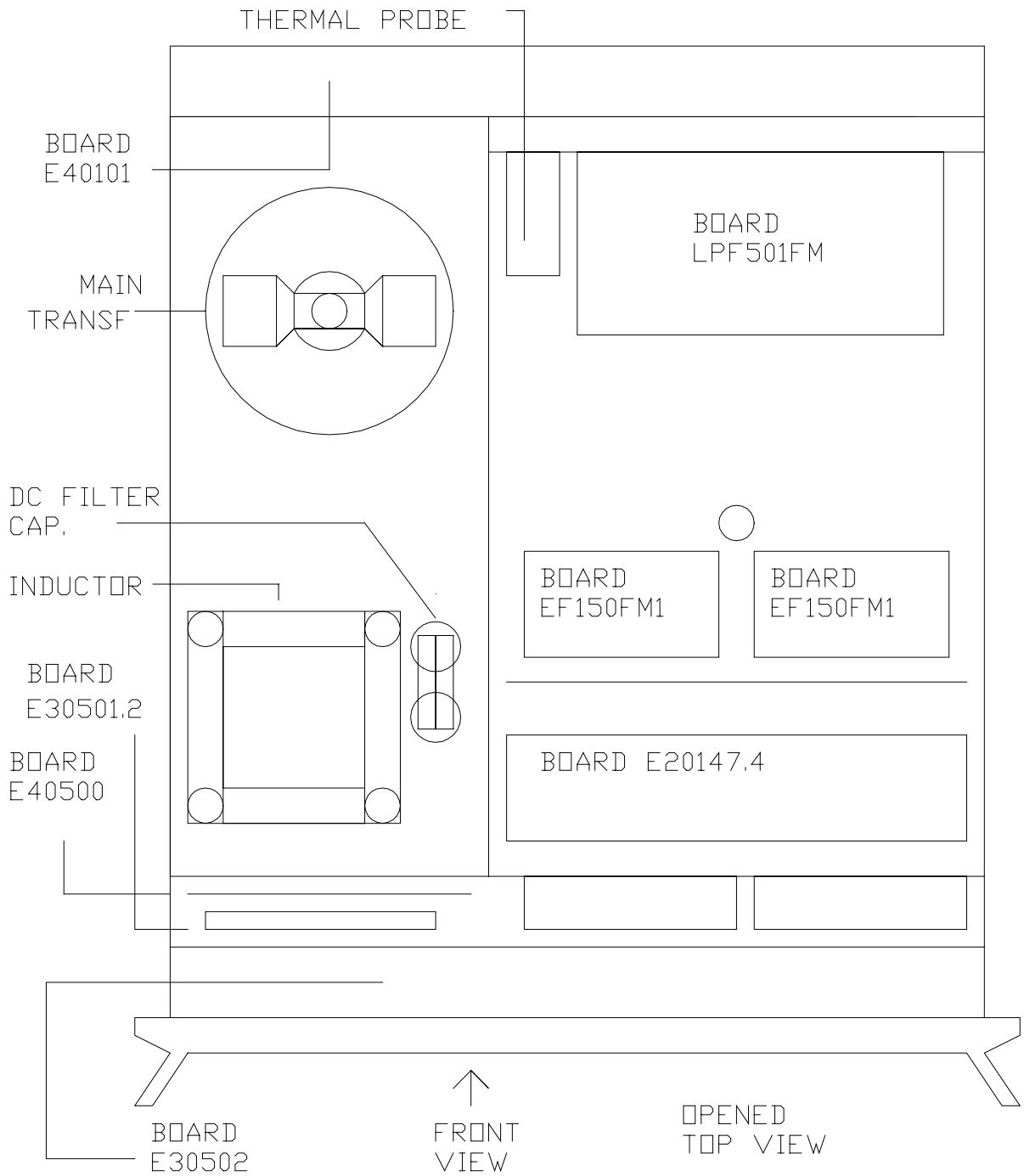

**BOTTOM VIEW**

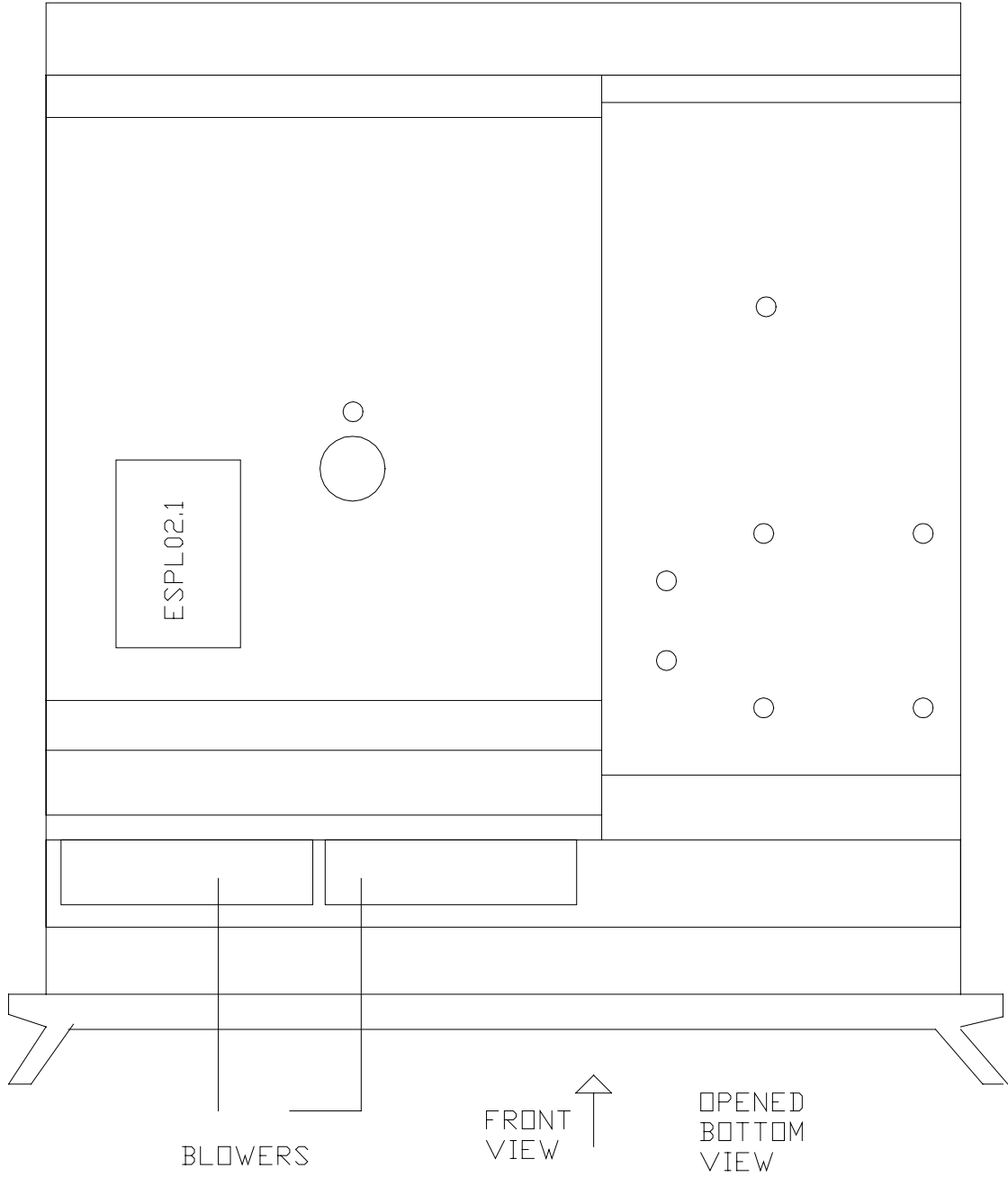

## R.F. BLOCK DIAGRAM

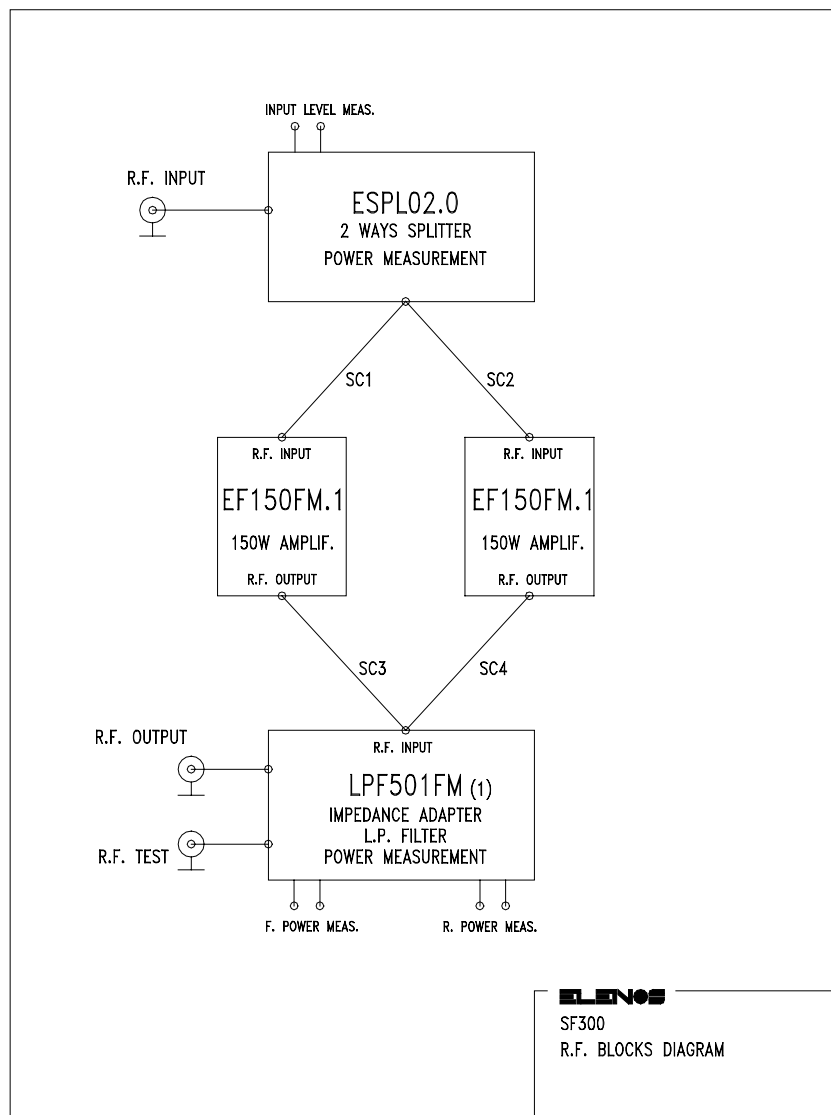

Part List of R.F. Block Diagram

Rif.	Description	Value	Remarks
ESPL06.0	Splitter input and power measurement board		
EF150FM.1	Power amplifier board		
LPF501FM	Low pass filter board		
SC1, SC2	Cable type RG178 50 ohm	1/4 wave length	
SC3, SC4	Cable type RG179 75 ohm	1/4 wave length	
R.F.INPUT	Coaxial connector type N female		
R.F.OUTPUT	Coaxial connector type N female		
R.F.TEST	Coaxial connector type BNC male		

**POWER SUPPLY AND MEASUREMENT BLOCK DIAGRAM**

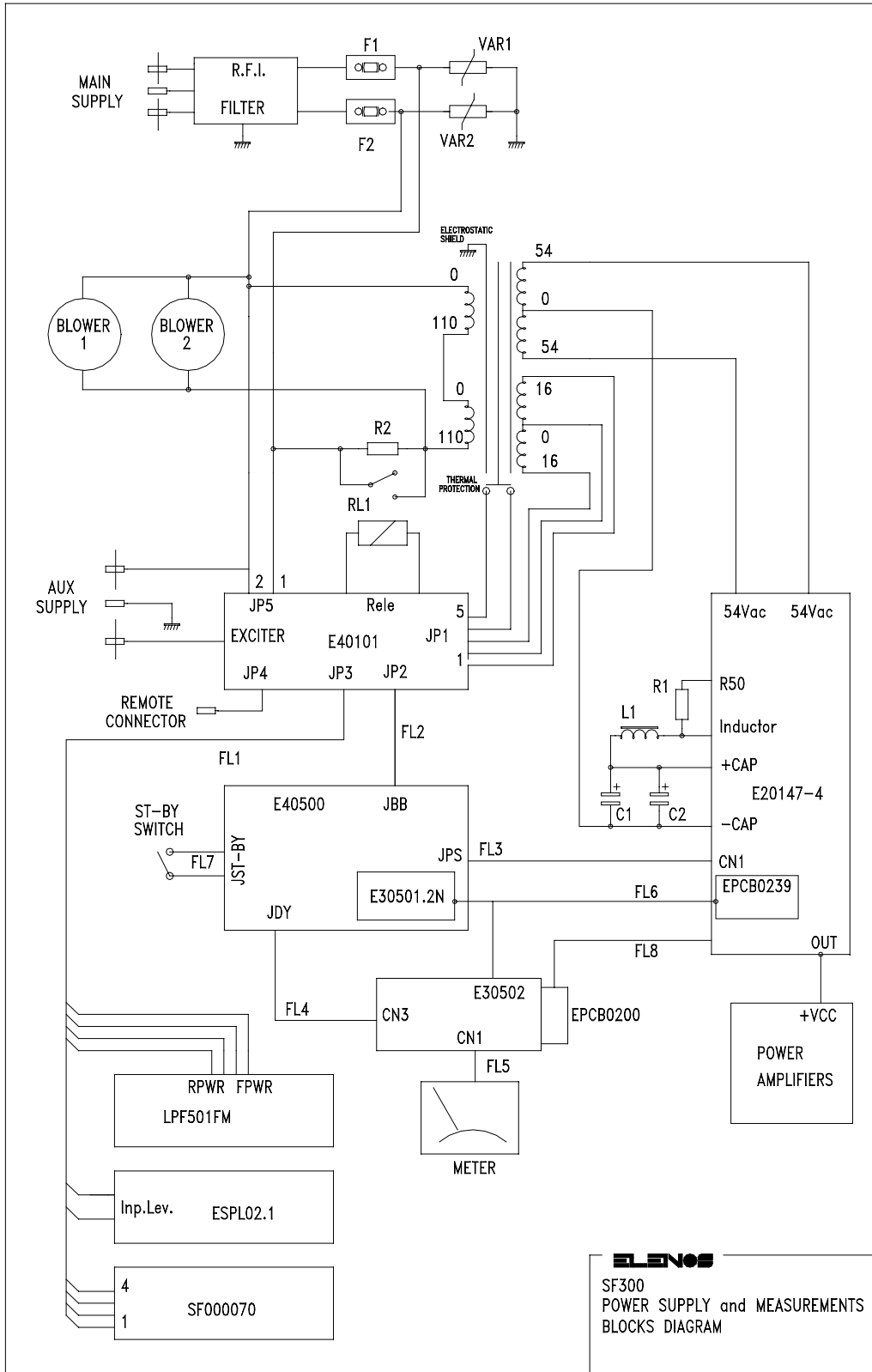



PART LIST OF POWER SUPPLY AND MEASUREMENT  
BLOCK DIAGRAM

Rif.	Description	Value	Remarks	Elenos Code
BLOWER 1, BLOWER 2	Blower 120x120 30W			
C1,C2	Electrolytic capacitor	4700 $\mu$ F	63V	
E20147-4	Power supply board			
E30501-2N	Protection board			
E30502	Front panel board			
E40101	Back board			
E40500	Connection board			
LPF501FM	Low pass filter			
ESPL02.1	2 ways splitter			
EPCB0200	Clock buffer Board			
EPCB0239	Watch-Dog Board			
F1, F2	Fuse holder with 10A fuse			
FL1	Flat Cable 10 pin			CSF- F006
FL2	Flat Cable 40 pin			CSF- F007
FL3	Flat Cable 20 pin			CSF- F008
FL4	Flat Cable 20 pin			CSF- F004
FL5	Flat Cable 2 pin			CSF- F016
FL6	Flat Cable 2 pin			CSF- 0024
FL7	Flat Cable 4 pin			CSF- F005
FL8	Cable type RG178	35 cm		
L1	Inductor	750 $\mu$ H	11 A	
Meter	Meter 100 $\mu$ A f.s. M3D			
R1	Wire wound resistor	50 $\Omega$	5%	
R2	Resistor	10 $\Omega$	25W 5%	
RL1	Relay FINDER type 65.31	12 V DC		
R.F.I. filter	Arcotronics FAMDB3600ZE			
ST-BY SWITCH	2-way 2-position switch	250V 6A		
SF000070	Thermal Probe Board			
Transformer	Toroidal transformer with electrostatic shield	900 VA		
VAR1, VAR2	MOV type S20K-275			

## LAYOUT OF COMPONENTS

### ESPL02.1 (Splitter input Board)

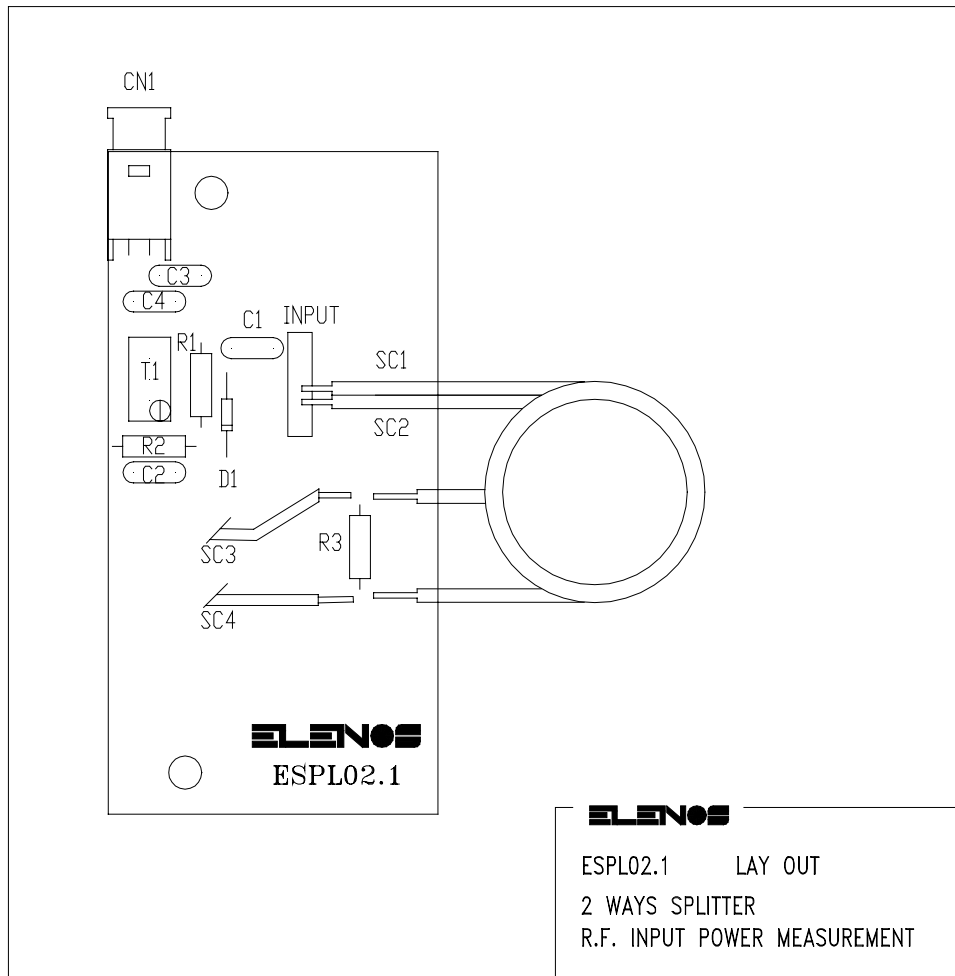

Part List of ESPL02.1 Board

Rif.	Description	Value	Remarks	Elenos Code
PCB	Print Board			2PCB0210
R1, R2	Resistor	34 K $\Omega$	1%	
R3	Resistor	100 $\Omega$	2W	
T1	Trimmer type 67W	50 K $\Omega$		
C1, C2	Ceramic Capacitor	10 pF	50 V	
C3, C4	Ceramic Capacitor	4n7	50 V	
D1	Diode Germanium	AA118		
SC1, SC2	Cable type RG179 75 ohm	$\frac{1}{4}$ wave length		
SC3, SC4	Cable type RG178 50 ohm	$\frac{1}{4}$ wave length		
CN1	Connector AMP MODU II 2 pin angled			

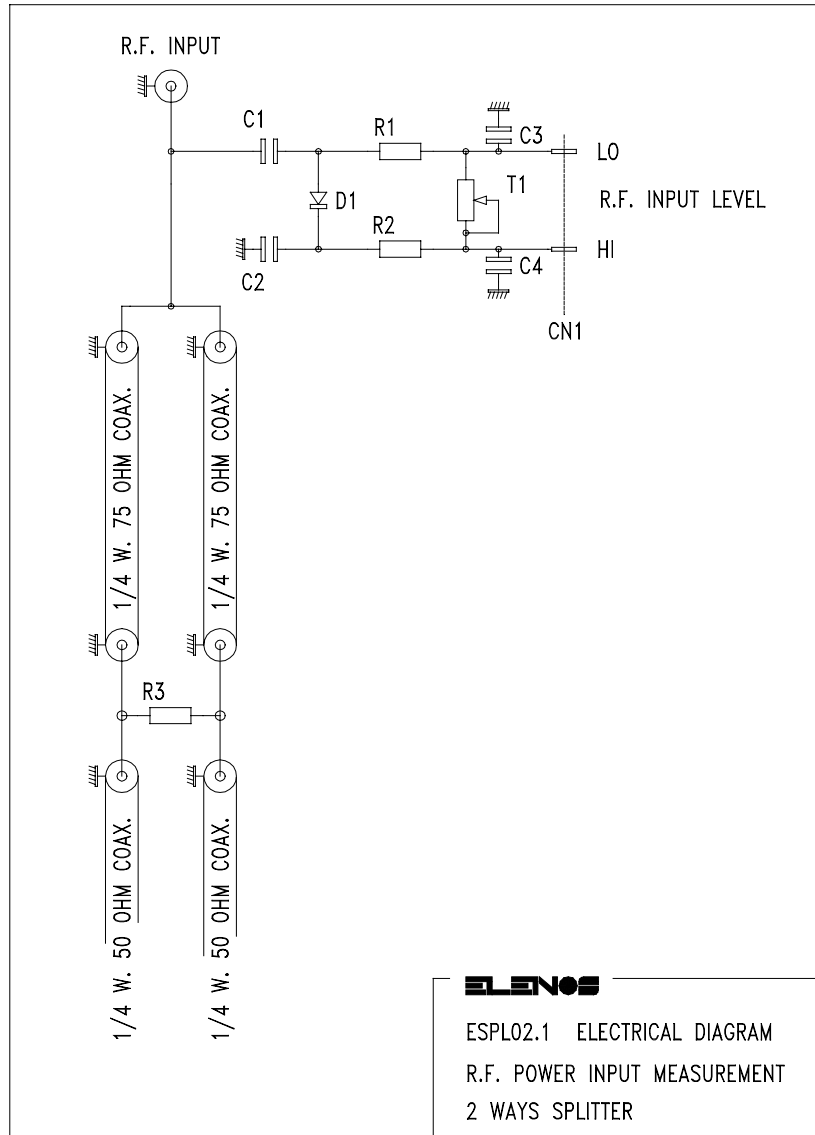

**EF150FM.1 (Power Amplifier)**

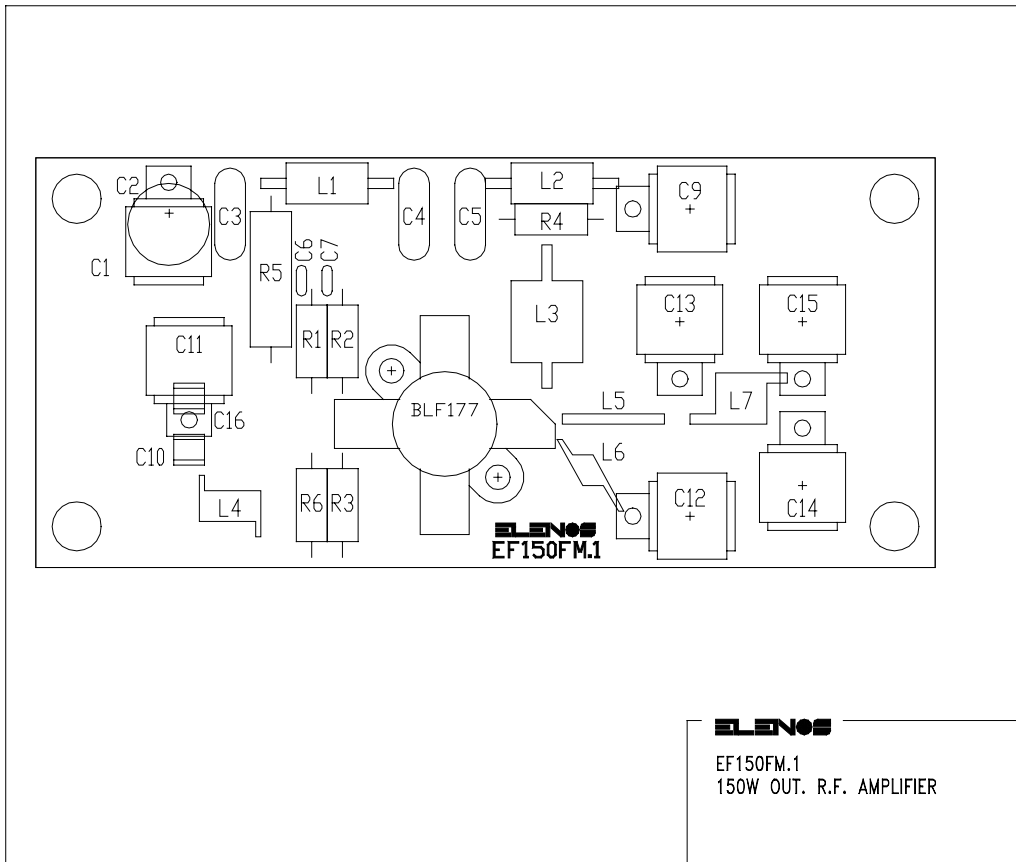

**ELENOS**  
EF150FM.1  
150W OUT. R.F. AMPLIFIER

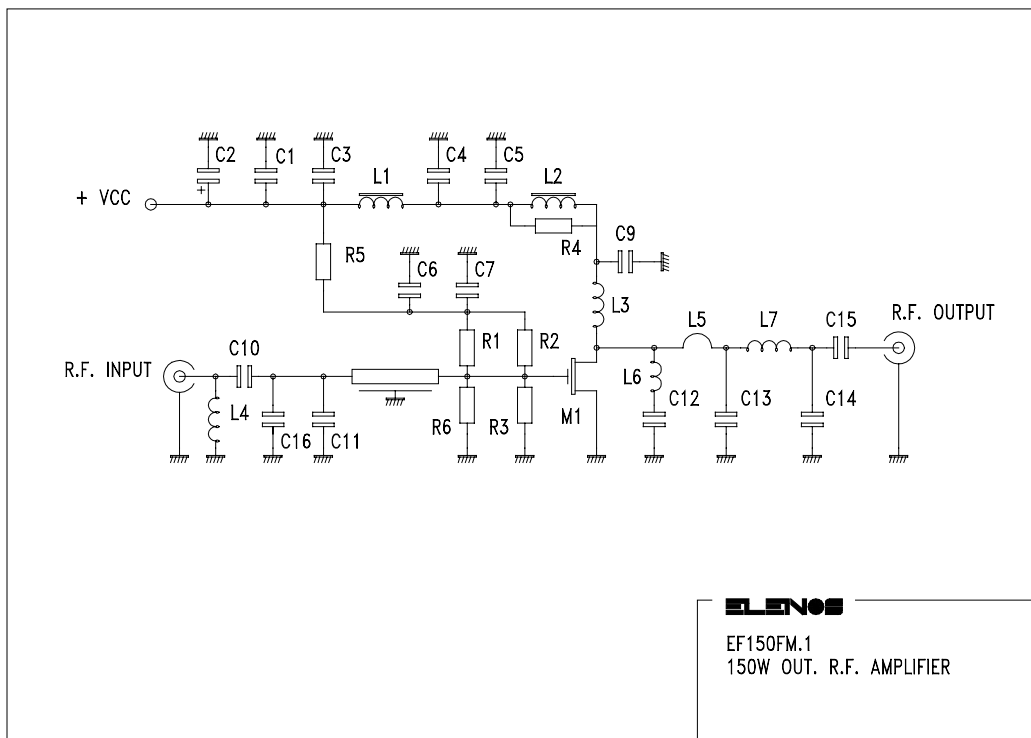

PART LIST BOARD EF150FM1

Rif.	Description	Value	Remarks	Elenos Code
PCB				2PCB0190
R1, R2	Resistor	100 $\Omega$	0.5 W 5%	
R3	Resistor	820 $\Omega$	0.25 W 5%	
R4	Resistor	10 $\Omega$	2 W 5%	
R5	Resistor	15 K $\Omega$	0.25 W 5%	
R6	Resistor	2k7	0.25 W 5%	
C1	Mica Capacitor	1000 pF	500 V	
C2	Electrolytic. Vert. Capacitor	47 $\mu$ F	63 V	
C3	Ceramic Capacitor	4n7	2 KV	
C4	Mylar Capacitor	220 nF	100 V	
C5	Ceramic Capacitor	4n7	2 KV	
C6, C7	Ceramic Capacitor SMD	4n7	50 V	
C9	Mica Capacitor	1000 pF	500 V	
C10	Ceramic Capacitor NPO	82 pF	100 V	
C11, C12	Mica Capacitor	330 pF	500 V	
C13	Mica Capacitor	220 pF	500 V	
C14	Mica Capacitor	47 pF	500 V	
C15	Mica Capacitor	1000 pF	500 V	
C16	Ceramic Capacitor NPO	82 pF	100 V	
L1, L2	Inductor type VK200	200 $\mu$ H		
L3	Coil #8 turns D=8.0 W=1.0			2L000110
L4	Coil #3 turns D=5.0 W=1.0			2L000100
L5	Coil #0.5 turns D=8.5 W=1.0			2L000140
L6	Coil #2 turns D=5.0 W=1.0			2L000130
L7	Coil #3 turns D=6.5 W=1.0			2L000120
M1	Mosfet type BLF177			

LPF501FM (Low Pass Filter)

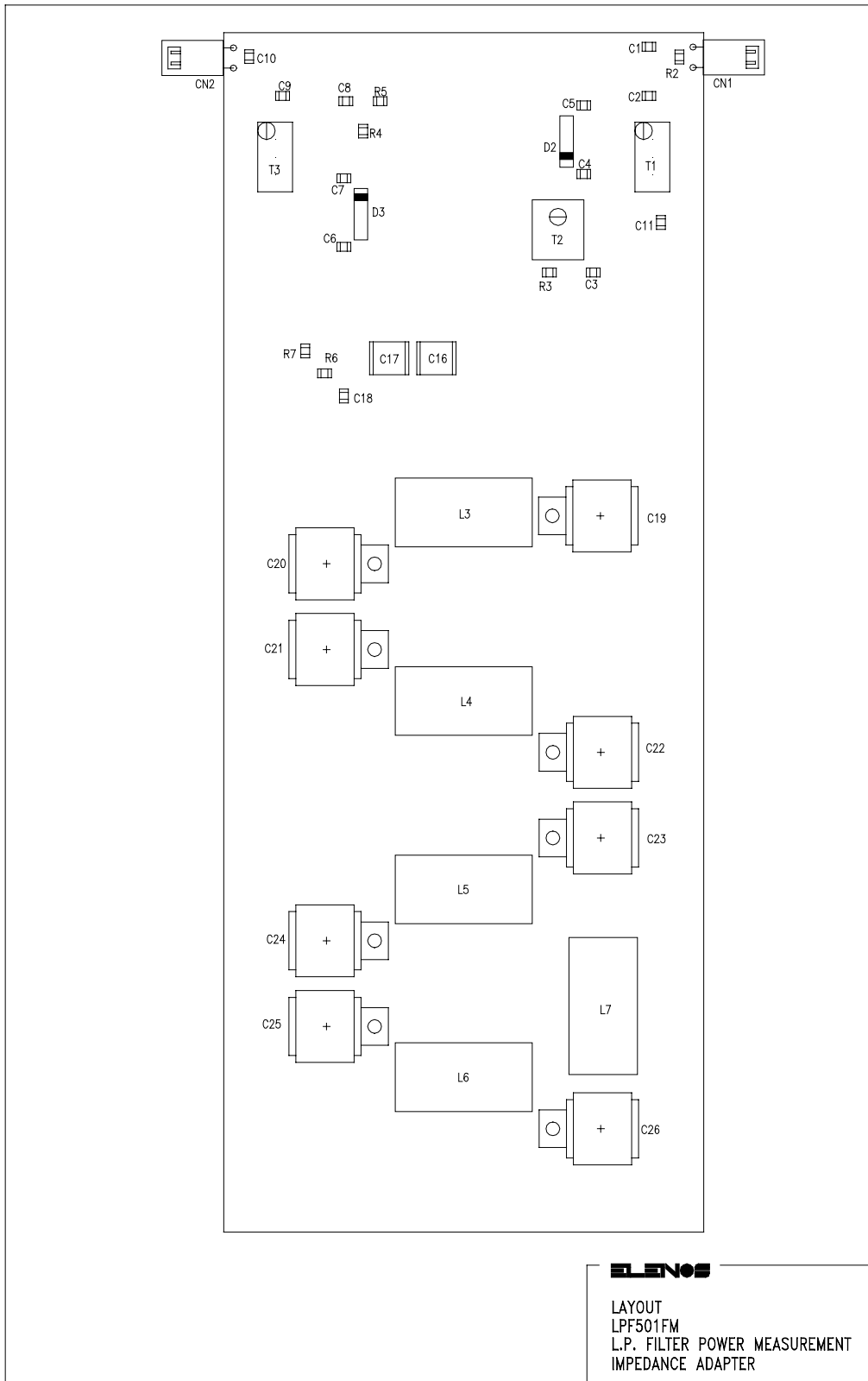

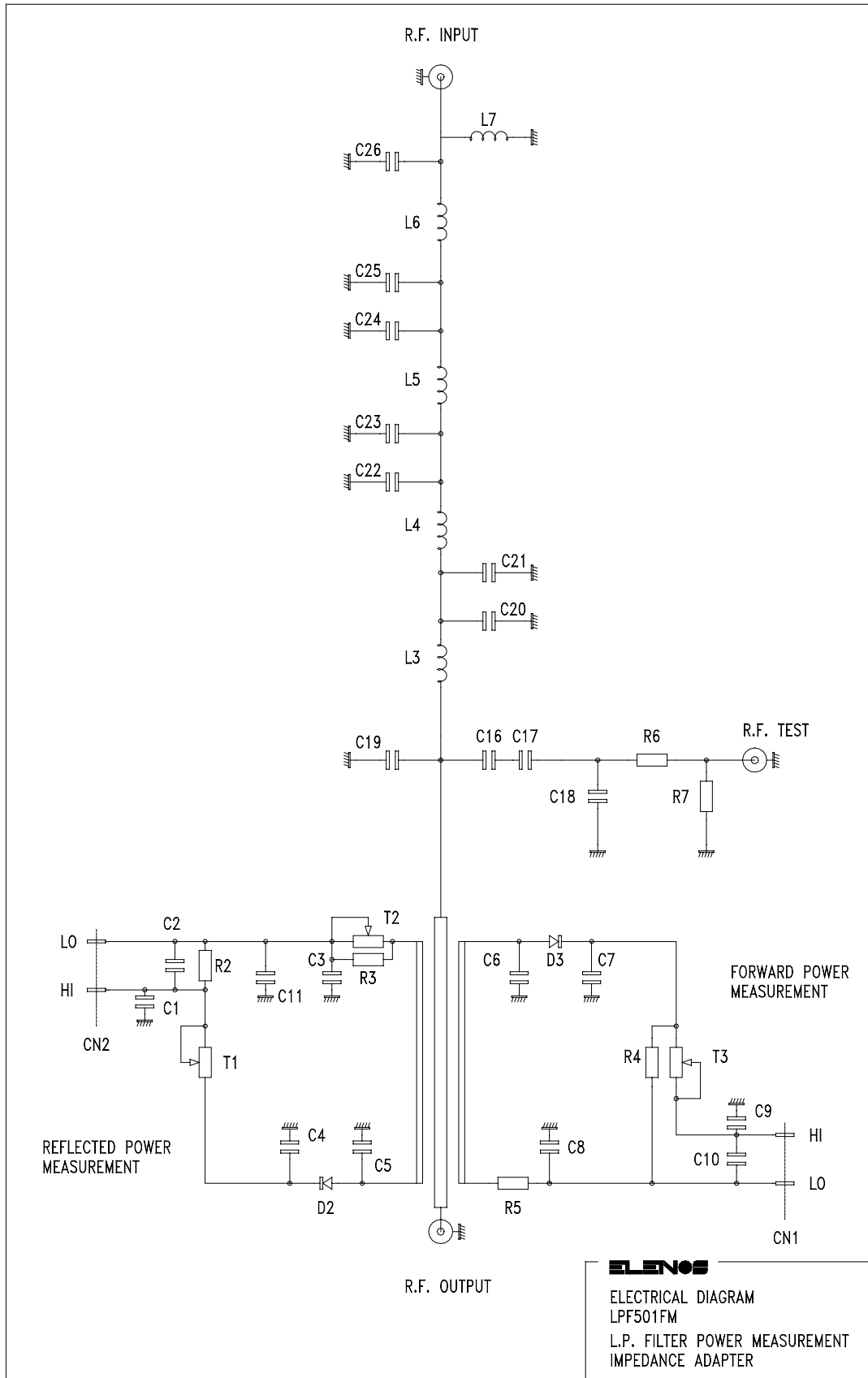

PART LIST BOARD LPF501FM

Rif.	Description	Value	Remarks	Elenos Code
PCB	Board LPF501FM			2PCB0225
R2, R6	CHIP Resistor S.1206	220 $\Omega$		
R3	CHIP Resistor S.1206	270 $\Omega$		
R4	CHIP Resistor S.1206	3.3 K $\Omega$		
R5	CHIP Resistor S.1206	100 $\Omega$		
R7	CHIP Resistor S.1206	47 $\Omega$		
T1	Trimmer type 67W Beckman/Bourns	100 K $\Omega$		
T2	Trimmer type 72P Beckman/Bourns	500 $\Omega$		
T3	Trimmer type 67W Beckman/Bourns	50 K $\Omega$		
C1, C2, C3, C4, C7, C8, C9, C10, C11	Ceramic Capacitor	4n7	100V	
C5, C6	Ceramic Capacitor	47 pF	100V	
C16, C17	Ceramic Capacitor	1.5 pF	500V	
C18	Ceramic Capacitor	22 pF	100V	
C19, C20, C21, C22, C23, C24, C25, C26	Mica Capacitor	27 pF	500V	2CMI0027
L3, L6	Coil #4 turns D=8.5 W=1.5			2L000220
L4, L5	Coil #5 turns D=8.5 W=1.5			2L000230
L7	Coil #20 turns D=8.5 W=1.5			2L000250
D2, D3	Diode type 1N82AG			
CN1, CN2	Connector AMP MODU II 2 pin angled			



E20147 (Power Supply Board)

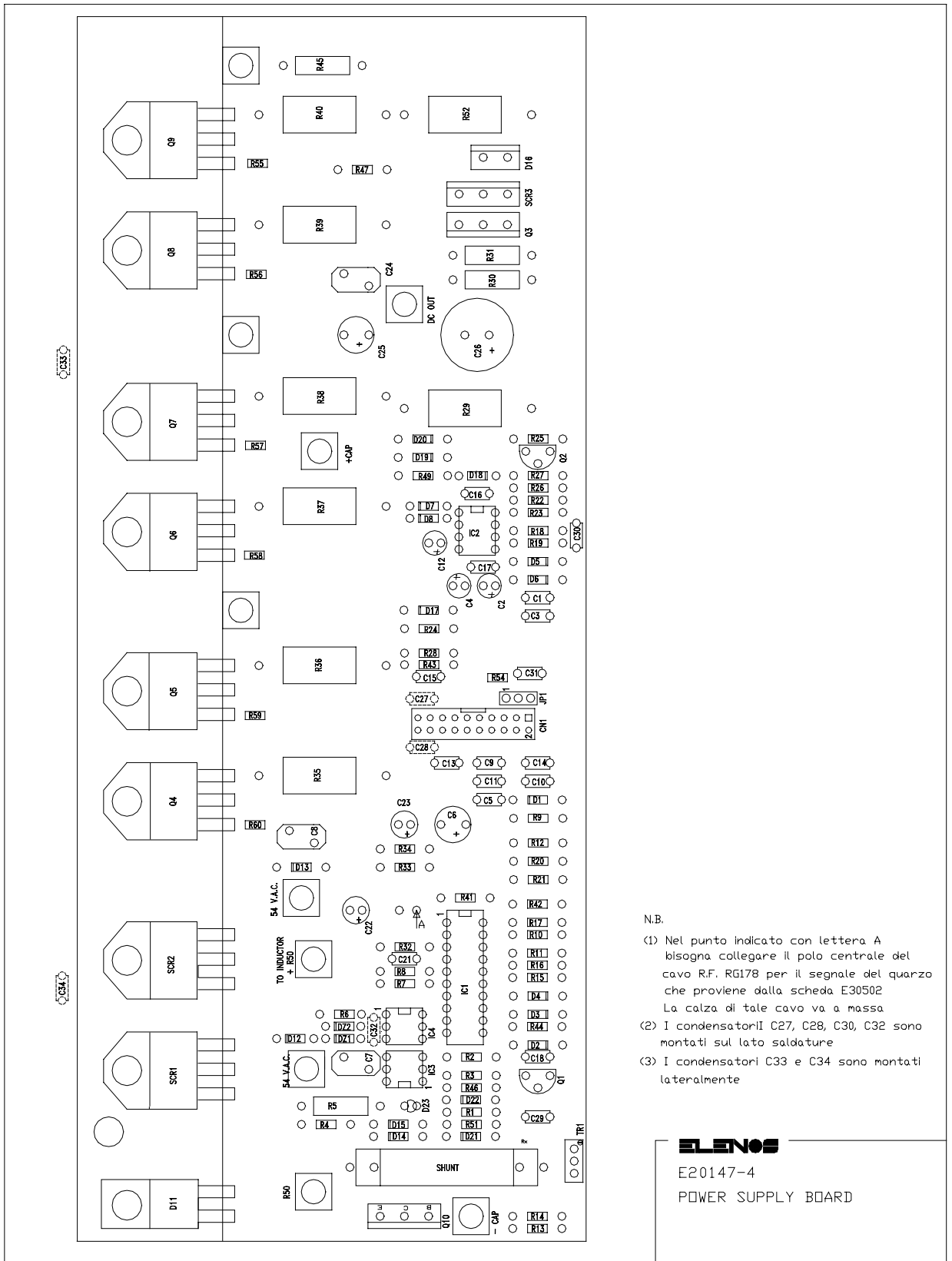

- N.B.
- (1) Nel punto indicato con lettera A bisogna collegare il polo centrale del cavo R.F. RG178 per il segnale del quarzo che proviene dalla scheda E30502 La calza di tale cavo va a massa
  - (2) I condensatori C27, C28, C30, C32 sono montati sul lato saldature
  - (3) I condensatori C33 e C34 sono montati lateralmente

**ELENOS**  
E20147-4  
POWER SUPPLY BOARD

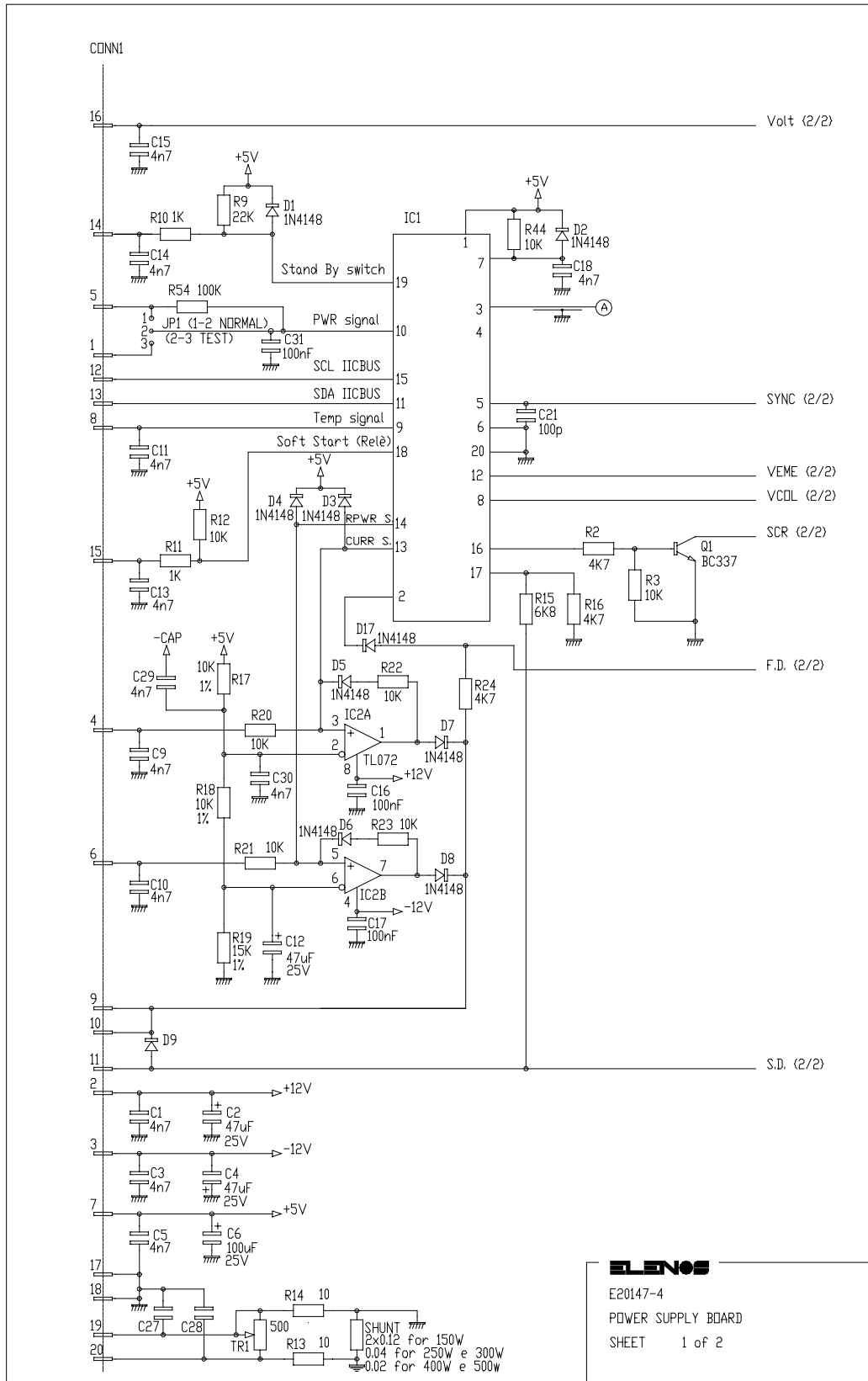

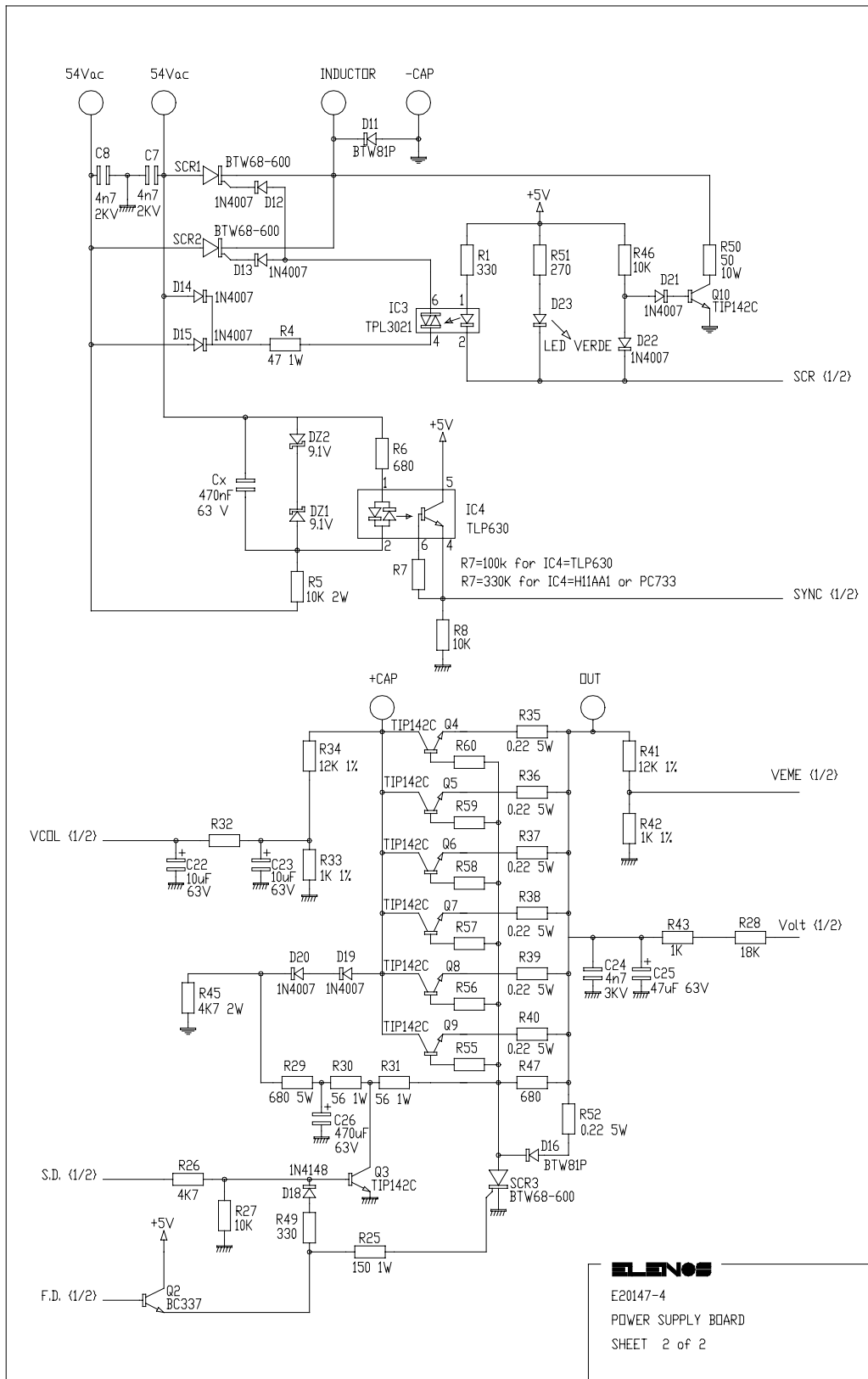

Part List Board E20147

Item	Description	Value	Remarks
PCB1	Board code 2PCB0224		
PCB2	Board code 2PCB0221		
R1	Resistor	330 Ω	1/4W 5%
R2	Resistor	4.7 KΩ	1/4W 1%
R3	Resistor	10 KΩ	1/4W 1%
R4	Resistor	47 Ω	1W 5%
R5	Resistor	10 KΩ	2W 5%
R6	Resistor	680 Ω	1/4W 5%
R7	Resistor	100 KΩ	1/4W 1%
R8	Resistor	10 KΩ	1/4W 1%
R9	Resistor	22 KΩ	1/4W 1%
R10, R11	Resistor	1KΩ	1/4W 1%
R12	Resistor	10 KΩ	1/4W 1%
R13, R14	Resistor	10 Ω	1/4W 1%
R15	Resistor	6.8 KΩ	1/4W 1%
R16	Resistor	4.7 KΩ	1/4W 1%
R17, R18	Resistor	10 KΩ	1/4W 1%
R19	Resistor	15 KΩ	1/4W 1%
R20, R21, R22, R23	Resistor	10 KΩ	1/4W 1%
R24	Resistor	4.7 KΩ	1/4W 1%
R25	Resistor	150 Ω	1W 5%
R26	Resistor	4.7 KΩ	1/4W 1%
R27	Resistor	10 KΩ	1/4W 1%
R28	Resistor	18 KΩ	1/4W 5%
R29	Resistor	680 Ω	5W 5%
R30, R31	Resistor	56 Ω	2W 5%
R32	Resistor	10 KΩ	1/4W 1%
R33	Resistor	1 KΩ	1/4W 1%
R34	Resistor	12 KΩ	1/4W 1%
R35, R36, R37, R38,R39, R40	Resistor	0.22 Ω	5 W 5%
R41	Resistor	12 KΩ	1/4W 1%
R42, R43	Resistor	1 KΩ	1/4W 1%
R44	Resistor	10 KΩ	1/4W 1%
R45	Resistor	4.7 KΩ	2 W 5%
R46	Resistor	10 KΩ	1/4W 1%
R47	Resistor	680 Ω	1/4W 5%
R49	Resistor	330 Ω	1/4W 5%
R51	Resistor	270 Ω	1/4W 5%
R52	Resistor	0.22 Ω	5 W 5%
R54	Resistor	100 K Ω	1/4W 1%
R55, R56, R57, R58, R59, R60	Resistor	100 Ω	1/4W 1%

SHUNT SF150	Resistor	0.12 $\Omega$	5W 1%
SHUNT SF250, SF300	Resistor	0.04 $\Omega$	5W 1%
SHUNT SF400	Resistor	0.02 $\Omega$	5W 1%
SHUNT SF500, HF1000	Resistor	0.02 $\Omega$	5W 1%
TR1	Trimmer Vert. Mult. Type 67W	500 $\Omega$	
C1, C3, C5	Ceramic Capacitor	4n7	50V
C2, C4	Electrolytic. Vert. Capacitor	47 $\mu$ F	35V
C6	Electrolytic. Vert. Capacitor	100 $\mu$ F	35V
C7, C8	Ceramic Capacitor	4n7	2KV
C9, C10, C11	Ceramic Capacitor	4n7	50V
C12	Electrolytic. Vert. Capacitor	47 $\mu$ F	35V
C13, C14, C15	Ceramic Capacitor	4n7	50V
C16, C17	Ceramic Capacitor Multis.	100 nF	50 V
C18	Ceramic Capacitor	4n7	50V
C21	Ceramic Capacitor	100 pF	50 V
C22, C23	Electrolytic. Vert. Capacitor	10 $\mu$ F	63 V
C24	Ceramic Capacitor	4n7	2KV
C25	Electrolytic. Vert. Capacitor	47 $\mu$ F	63 V
C26	Electrolytic. Vert. Capacitor	470 $\mu$ F	63 V
C27, C28, C29, C30	Ceramic Capacitor	4n7	50V
C31	Polyester Capacitor	220 nF	63 V
C32	Polyester Capacitor	470 nF	63 V
C33, C34	Ceramic Capacitor	4n7	2KV
D1, D2, D3, D4, D5, D6, D7, D8	Diode type 1N4148		
D11	Diode type BTW81P or RUR1520 + Mica Insulator + Insulating Ring		
D12, D13, D14, D15	Diode type 1N4007		
D16	Diode type BTW81P		
D17, D18	Diode type 1N4148		
D19 - D22	Diode type 1N4007		
D23	Green Led 3 mm.		
DZ1, DZ2	Zener diode 9.1 V.		
Q1, Q2	Transistor type BC337		
Q3	Transistor type TIP142C		
Q4, Q5, Q6, Q7, Q8, Q9	Transistor type TIP142C + Mica Insulator + Insulating Ring		
Q10	Transistor type TIP142C		
SCR1, SCR2, SCR3	SCR type BTW68-600		25A 600V

IC1	ST62T10B6/HWD + Socket 20 pin		
IC2	MOC072C + Socket 8 pin		
IC3	Opto TLP3021 + Socket 6 pin		
IC4	Opto TLP630 + Socket 6 pin		
CN1	ANSLEY connector 2 x 10p		
-CAP	Fixing stud F/M 15mm. M3		
R50	Fixing stud F/M 15mm. M3		
54 V.A.C.	Fixing stud F/M 15mm. M3		
+R50	Fixing stud F/M 15mm. M3		
54 V.A.C.	Fixing stud F/M 15mm. M3		
+CAP	Fixing stud F/M 15mm. M3		
DC OUT	Fixing stud F/M 15mm. M3		
Heat Sink	Elenos code 9RSX0201		
JP1	Jumper 3 pin		

E30501.2N (Protection board)

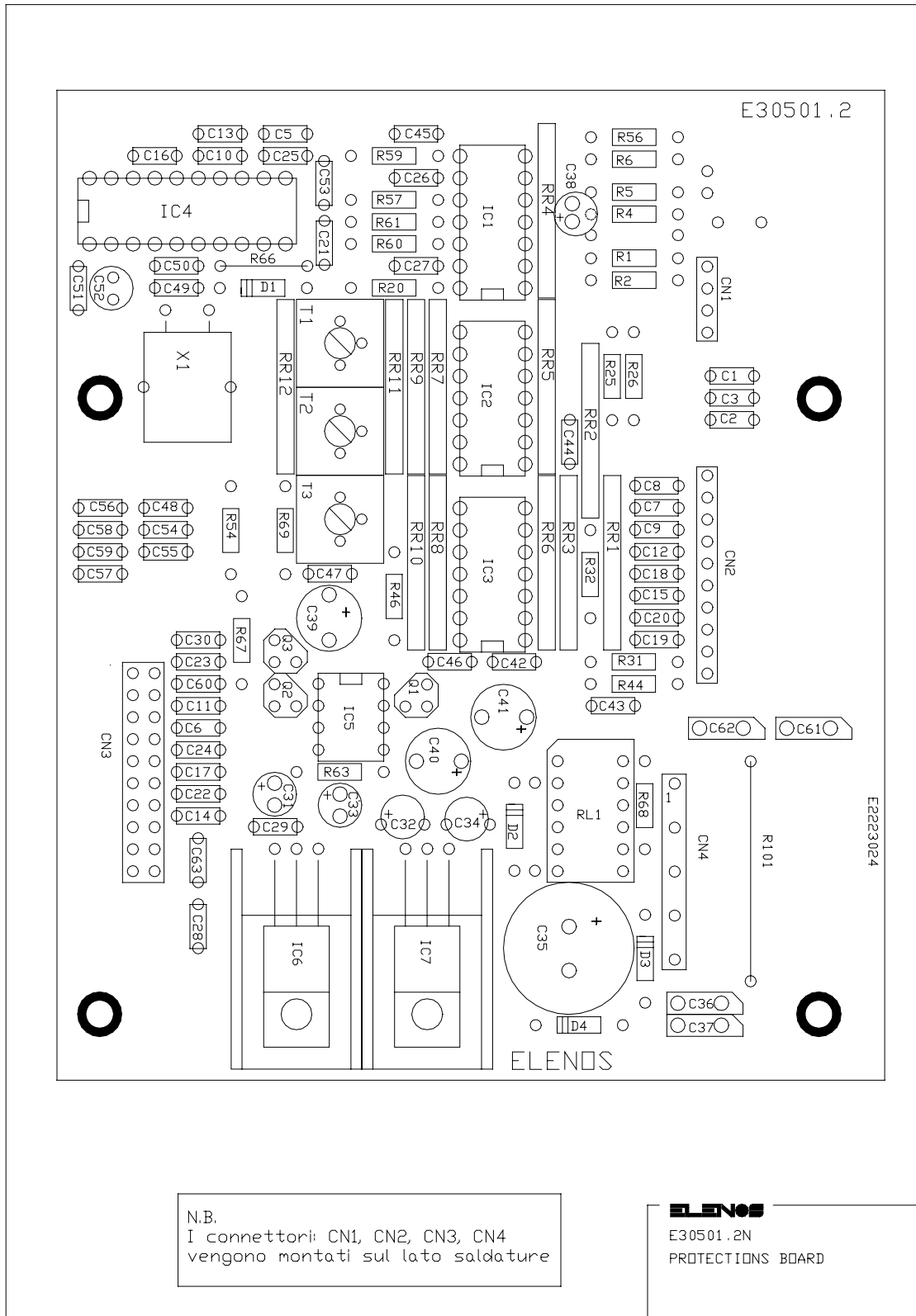

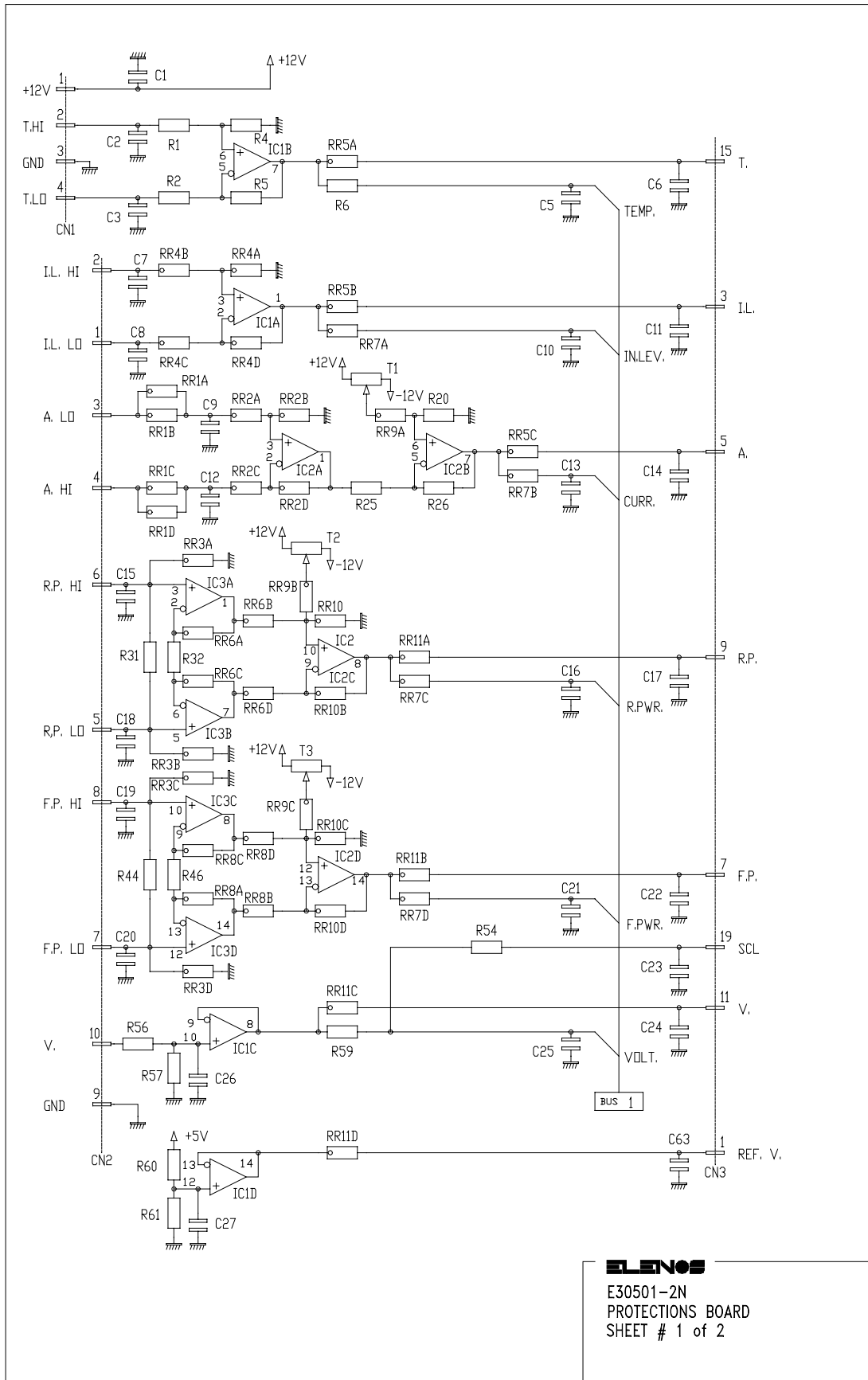

**ELENOS**  
 E30501-2N  
 PROTECTIONS BOARD  
 SHEET # 1 of 2



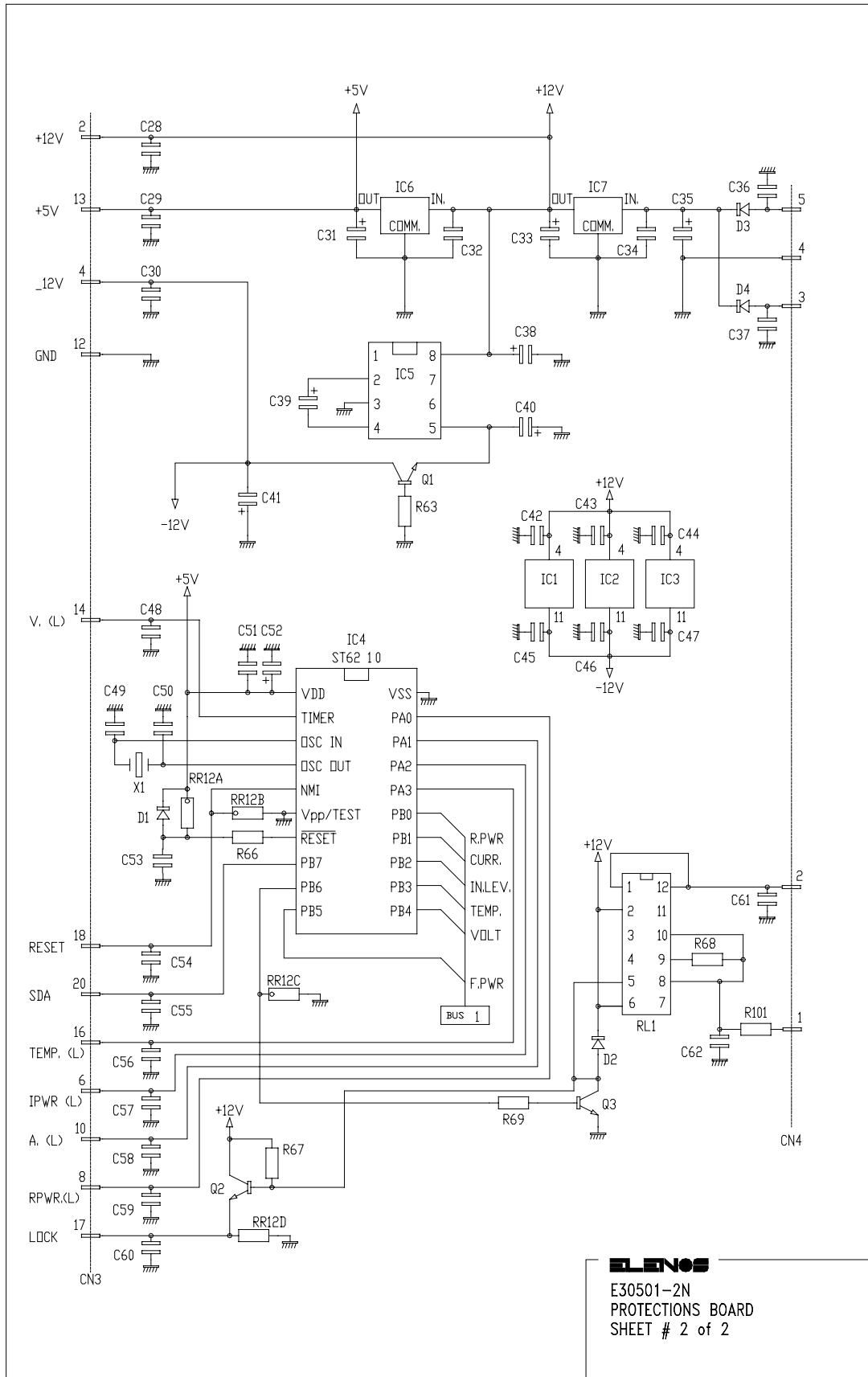

Part List Board E30501.2N

Rif.	Description	Value	Remarks
PCB	Board code 2PCB0206		
R1, R2	Resistor	10 K $\Omega$	¼ W 1%
R4, R5	Resistor	34 K $\Omega$	¼ W 1%
R6	Resistor	10 K $\Omega$	¼ W 1%
R20	Resistor	2.2 K $\Omega$	0.125 W
R25	Resistor	1.05 K $\Omega$	¼ W 1%
R26	Resistor	34 K $\Omega$	¼ W 1%
R31	Resistor	1.3 K $\Omega$	¼ W 1%
R32	Resistor	4.75 K $\Omega$	¼ W 1%
R44	Resistor	1.3 K $\Omega$	¼ W 1%
R46	Resistor	4.75 K $\Omega$	¼ W 1%
R54	Resistor	100 $\Omega$	¼ W 1%
R56	Resistor	100 K $\Omega$	¼ W 1%
R57	Resistor	4.75 K $\Omega$	¼ W 1%
R59	Resistor	10 K $\Omega$	¼ W 1%
R60	Resistor	34 K $\Omega$	¼ W 1%
R61	Resistor	22 K $\Omega$	¼ W 1%
R63	Resistor	4.75 K $\Omega$	¼ W 1%
R66	Copper wire	0 $\Omega$	
R67	Resistor	4.75 K $\Omega$	¼ W 1%
R68	Resistor	1 K $\Omega$	¼ W 1%
R69	Resistor	4.75 K $\Omega$	¼ W 1%
R101	Copper wire	0 $\Omega$	
RR1	Resistor Array 83S104	4 x 100 K $\Omega$	
RR2	Resistor Array 83S103	4 x 10 K $\Omega$	
RR3	Resistor Array 83S105	4 x 1 M $\Omega$	
RR4	Resistor Array 83S103	4 x 10 K $\Omega$	
RR5	Resistor Array 4X101J	4 x 100 $\Omega$	
RR6	Resistor Array 83S102	4 x 1 K $\Omega$	
RR7	Resistor Array 83S103	4 x 10 K $\Omega$	
RR8	Resistor Array 83S102	4 x 1 K $\Omega$	
RR9	Resistor Array 83S474	4 x 470 K $\Omega$	
RR10	Resistor Array 83S333	4 x 33K	
RR11	Resistor Array 4X101J	4 x 100 $\Omega$	
RR12	Resistor Array 83S103	4 x 10 K $\Omega$	
T1, T2, T3	Trimmer type X	100K $\Omega$	
C1, C2, C3	Ceramic Capacitor	4.7 nF	50V
C5 to C26	Ceramic Capacitor	4.7 nF	50V
C27	Ceramic Capacitor	100 nF	63V
C28, C29, C30	Ceramic Capacitor	4.7 nF	50V
C31	Electrolytic. Vert. Capacitor	10 $\mu$ F	63 V
C32	Electrolytic. Vert. Capacitor	1 $\mu$ F	35 V
C33	Electrolytic. Vert. Capacitor	10 $\mu$ F	63 V
C34	Electrolytic. Vert. Capacitor	1 $\mu$ F	35 V
C35	Electrolytic. Vert. Capacitor	1000 $\mu$ F	35 V
C36, C37	Ceramic Capacitor	4.7 nF	2KV
C38	Electrolytic. Vert. Capacitor	10 $\mu$ F	63 V

C39, C40, C41	Electrolytic. Vert. Capacitor	100uF	35 V
C42, C43, C44, C45, C46, C47	Ceramic Capacitor	100 nF	63 V
C48	Ceramic Capacitor	4.7 nF	50 V
C49, C50	Ceramic Capacitor	22 pF	63 V
C51	Ceramic Capacitor	100 nF	63 V
C52	Electrolytic. Vert. Capacitor	1 uF	63 V
C53, C54, C55, C56, C57, C58, C59, C60	Ceramic Capacitor	4.7 nF	50V
C61, C62	Ceramic Capacitor	4.7 nF	2KV
C63	Ceramic Capacitor	4.7 nF	50V
D1	Diode type 1N4148		
D2, D3, D4	Diode type 1N4007		
Q1, Q2, Q3	Transistor type BC337		
IC1, IC2, IC3	I.C. type TL074 + Socket 14 pin		
IC4	ST62T10B6/HWD + Socket 20 pin + Epcb0240 Board		
IC5	LT1054CNB + Socket 8 pin		
IC6	T7805CT + Heat-sink 21C / W		
IC7	T7812CT + Heat-sink 21C / W		
RL1	Relay Siemens V23101-D0106-B201		
X1	Crystal 8MHz		
CN1	Strip step 2.54	1 x 4p	
CN2	Strip step 2.54	1 x 10p	
CN3	Strip step 2.54	2 x 10p	
CN4	Strip step 5.08	1 x 5	or 1 x 9 step 2.54

E30502 (Front panel board)

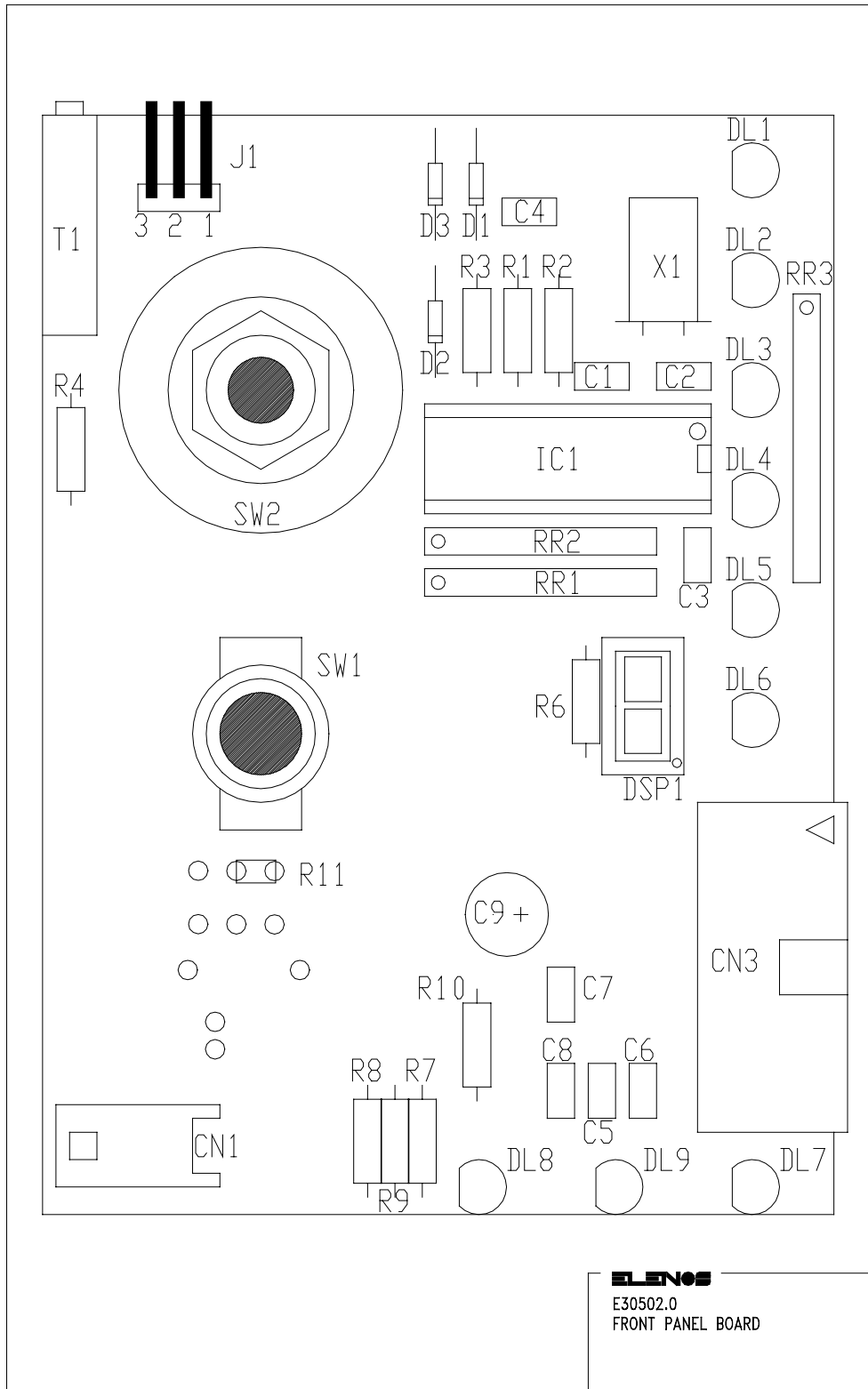

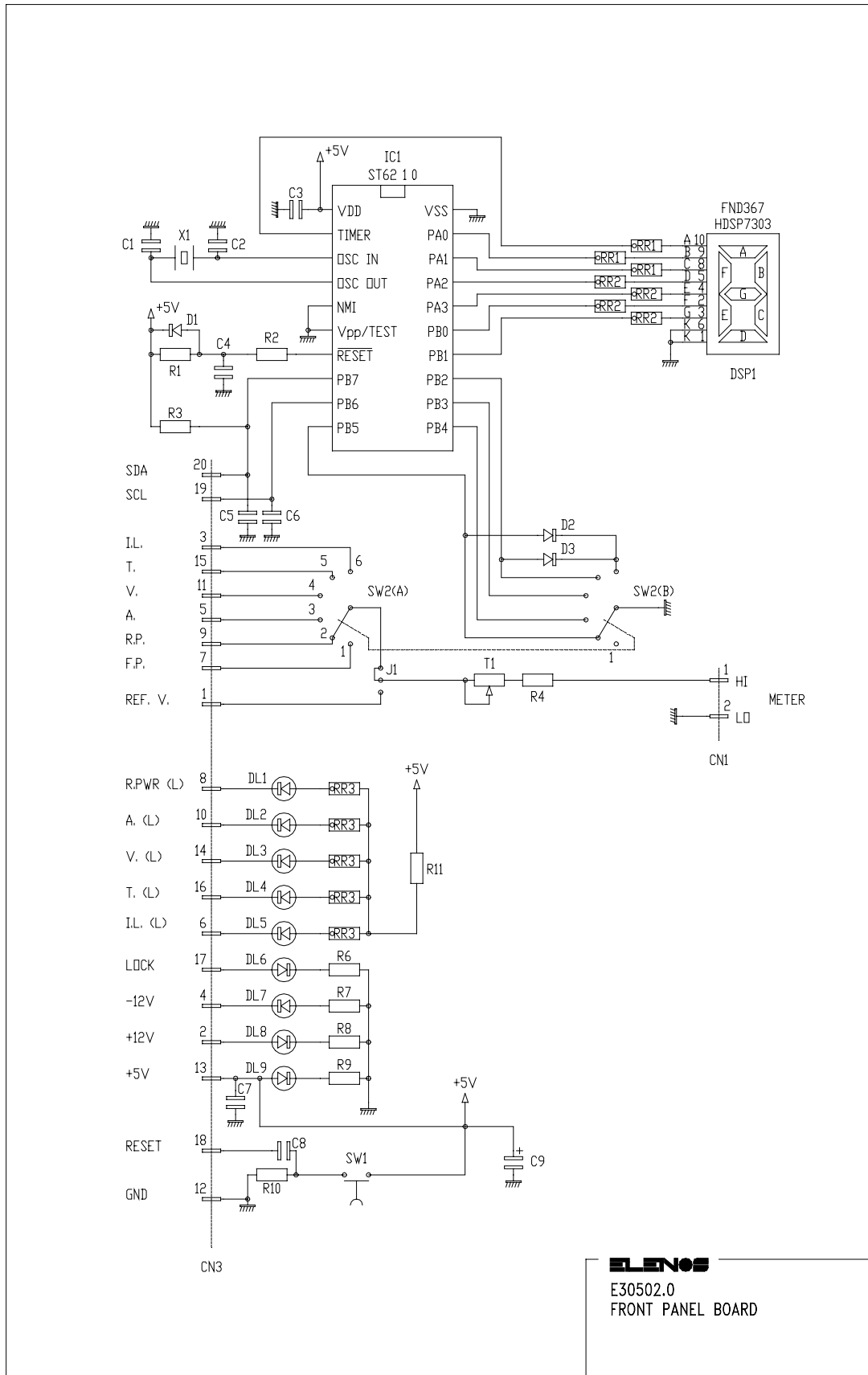

**ELENOS**  
E30502.0  
FRONT PANEL BOARD

Part List Board E30502

Rif.	Description	Value	Remarks
PCB	Board Code 2PCB0207		
R1	Resistor	10 K $\Omega$	1/4W 1%
R2	Copper Wire	0 $\Omega$	
R3, R4	Resistor	10 K $\Omega$	1/4W 1%
R6	Resistor	1.8 K $\Omega$	1/4W 5%
R7, R8	Resistor	1 K $\Omega$	1/4W 1%
R9	Resistor	330 $\Omega$	1/4W 1%
R10	Resistor	10 K $\Omega$	1/4W 1%
R11	Copper Wire	0 $\Omega$	
RR1, RR2	Resistor Array	4 x 680 $\Omega$	
RR3	Resistor Array	9 x 470 $\Omega$	
T1	Trimmer type 89P	20 K $\Omega$	
C1, C2	Ceramic Capacitor	22 pF	50V
C3	Ceramic Capacitor	100 nF	63 V
C4, C5, C6, C7	Ceramic Capacitor	4n7	50V
C8	Ceramic Capacitor	10 nF	50V
C9	Electrolytic. Vert. Capacitor	100 uF	35V
D1, D2, D3	Diode type 1N4148		
DL1, DL2, DL3, DL4, DL5, DL6	Red Led 5 mm.		
DL7, DL8, DL9	Green Led 5 mm.		
DSP1	Display type FND367		
IC1	ST62T10B6/HWD +Socket 20 pin		
CN1	AMP connector MODU II 2p angled		
CN3	ANSLEY connector 10+10 pin straight		
J1	Jumper 3 pin		
SW1	push-button		
SW2	Rotary Switch 6 pos. 2 way		

E40101 (back board)

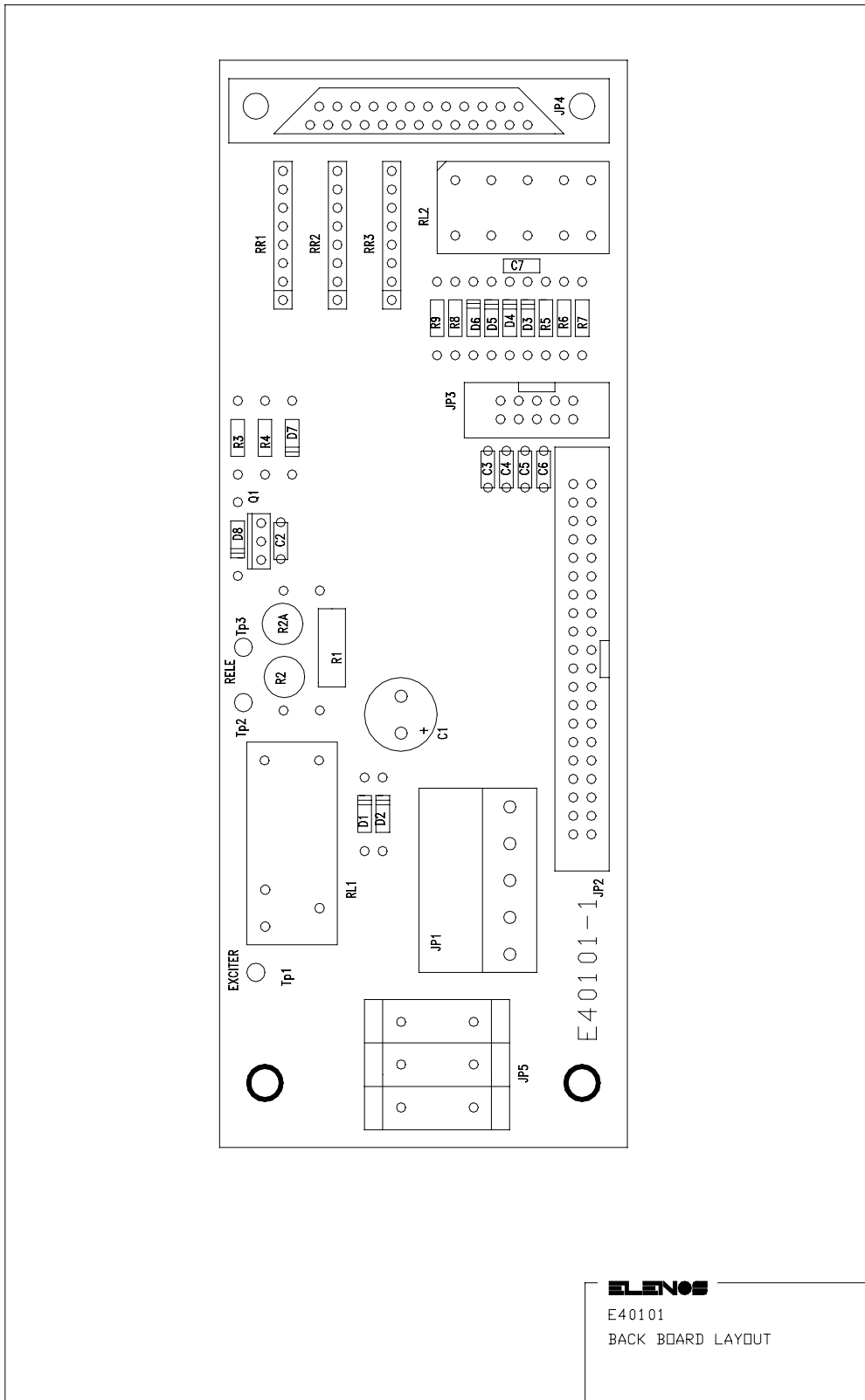

**ELENOS**  
E40101  
BACK BOARD LAYOUT

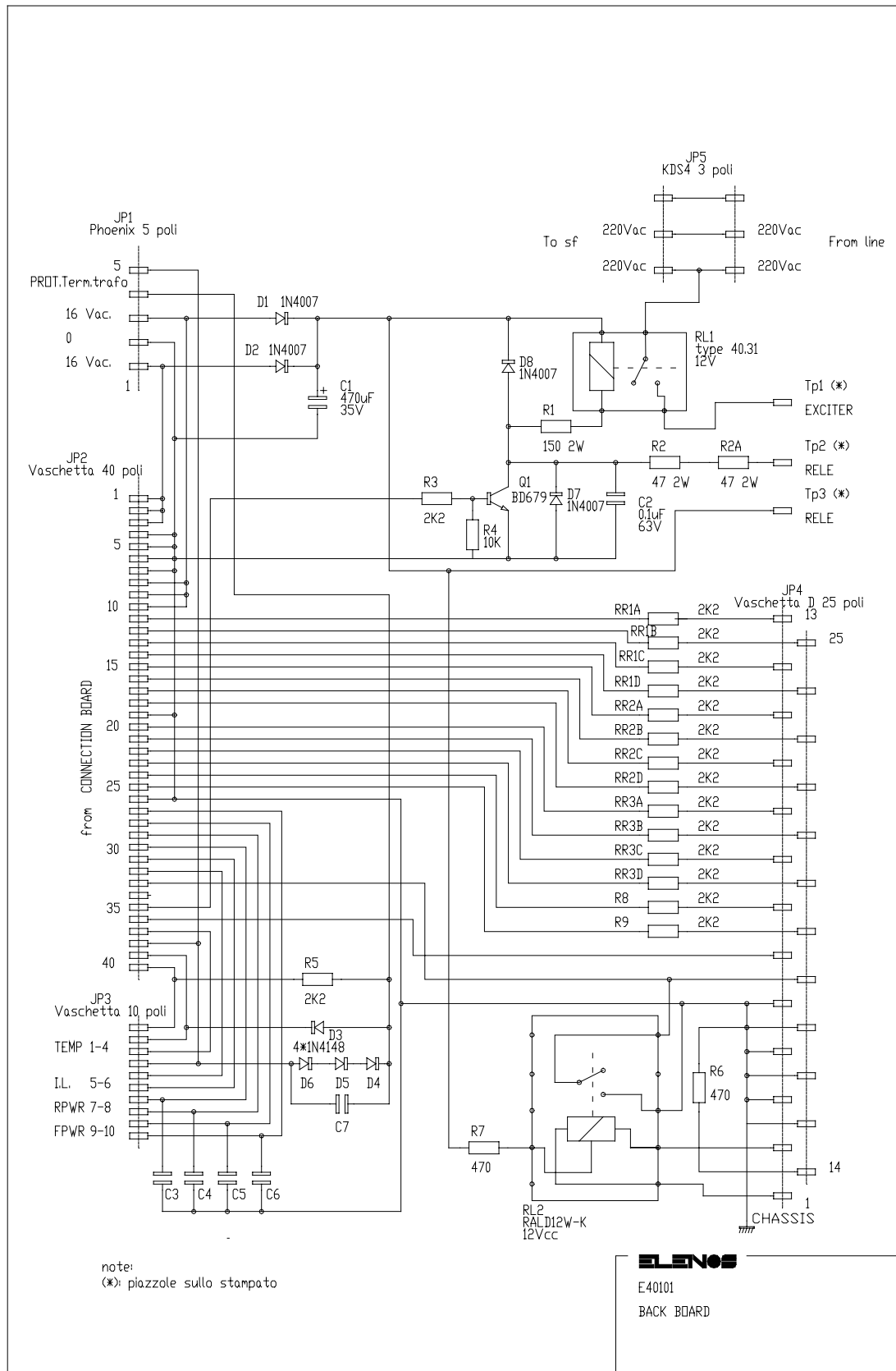



PART LIST BOARD E40101

Rif.	Description	Value	Remarks
PCB	Board code 2PCB0231		
R1	Resistor	150 $\Omega$	2 W 5%
R2, R2A	Resistor	47 $\Omega$	2 W 5%
R3	Resistor	1 K $\Omega$	1/4W 1%
R4	Resistor	10 K $\Omega$	1/4W 1%
R5	Resistor	2k2	1/4W 5%
R6, R7	Resistor	470 $\Omega$	1/2W 5%
R8, R9	Resistor	2k2	1/4W 5%
RR1, RR2, RR3	Resistor Array L83S222	4 x 2k2	8 pin
C1	Electrolytic. Vert. Capacitor	470 $\mu$ F	50 V 10%
C2	Ceramic Capacitor p5	100 nF	50 V 10%
C3, C4, C5, C6, C7	Ceramic Capacitor p5	4n7	50 V
D1, D2	Diode type 1N4007		
D3, D4, D5, D6	Diode type 1N4148		
D7, D8	Diode type 1N4007		
Q1	Transistor Darlington BD679		
RL1	Relay FINDER 40.31-12V DC		
RL2	Relay TAKAMISAWA RALD12W-K		
JP1	PHOENIX connector 5p Straight		
JP2	ANSLEY male connector 20+20 pin straight		
JP3	ANSLEY male connector 5+5 pin Straight		
JP4	Female connector type DB 25 pin straight		
JP5	PHOENIX connector type KDS4 3 pair pin		

### E40500 (connection board)

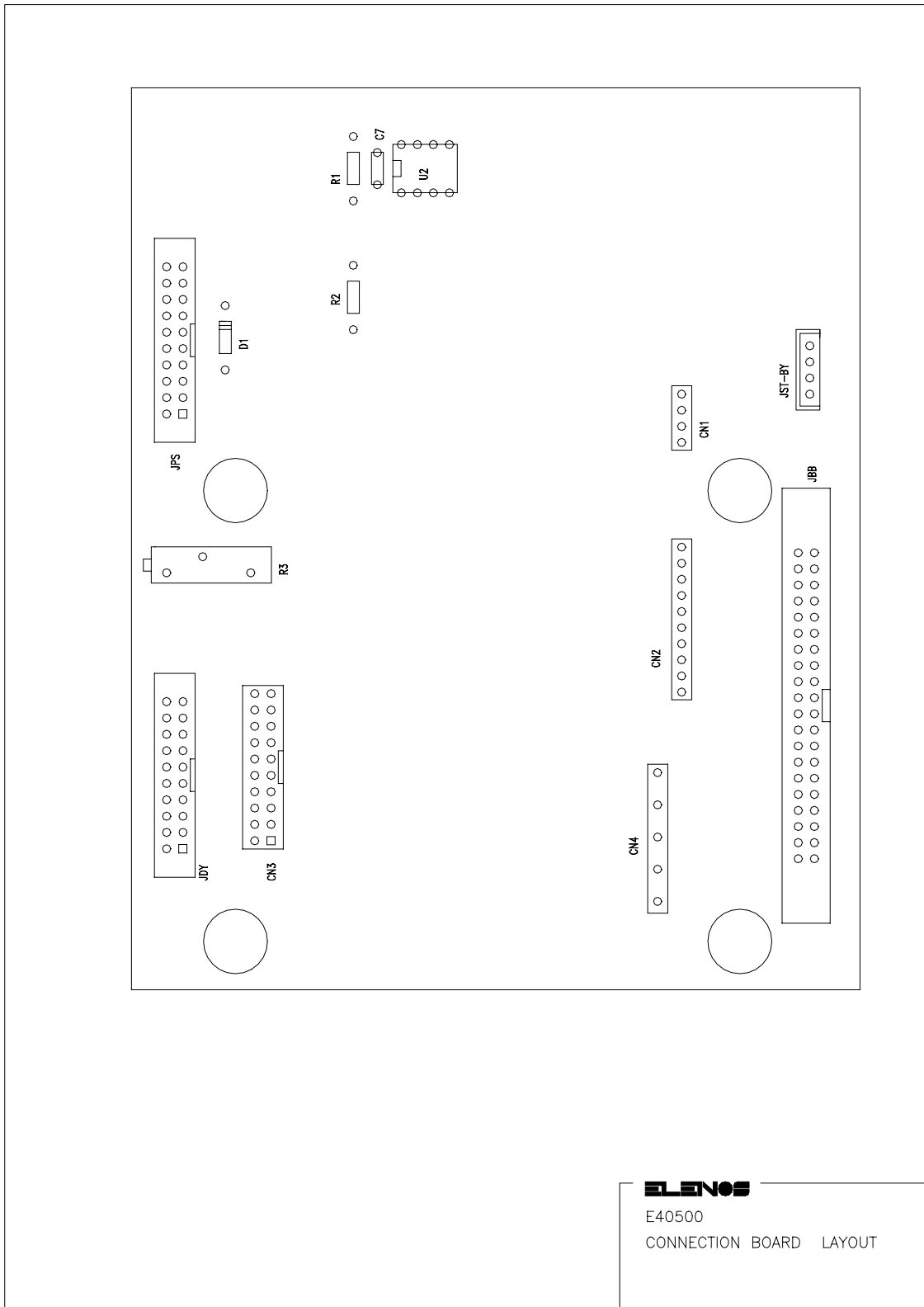

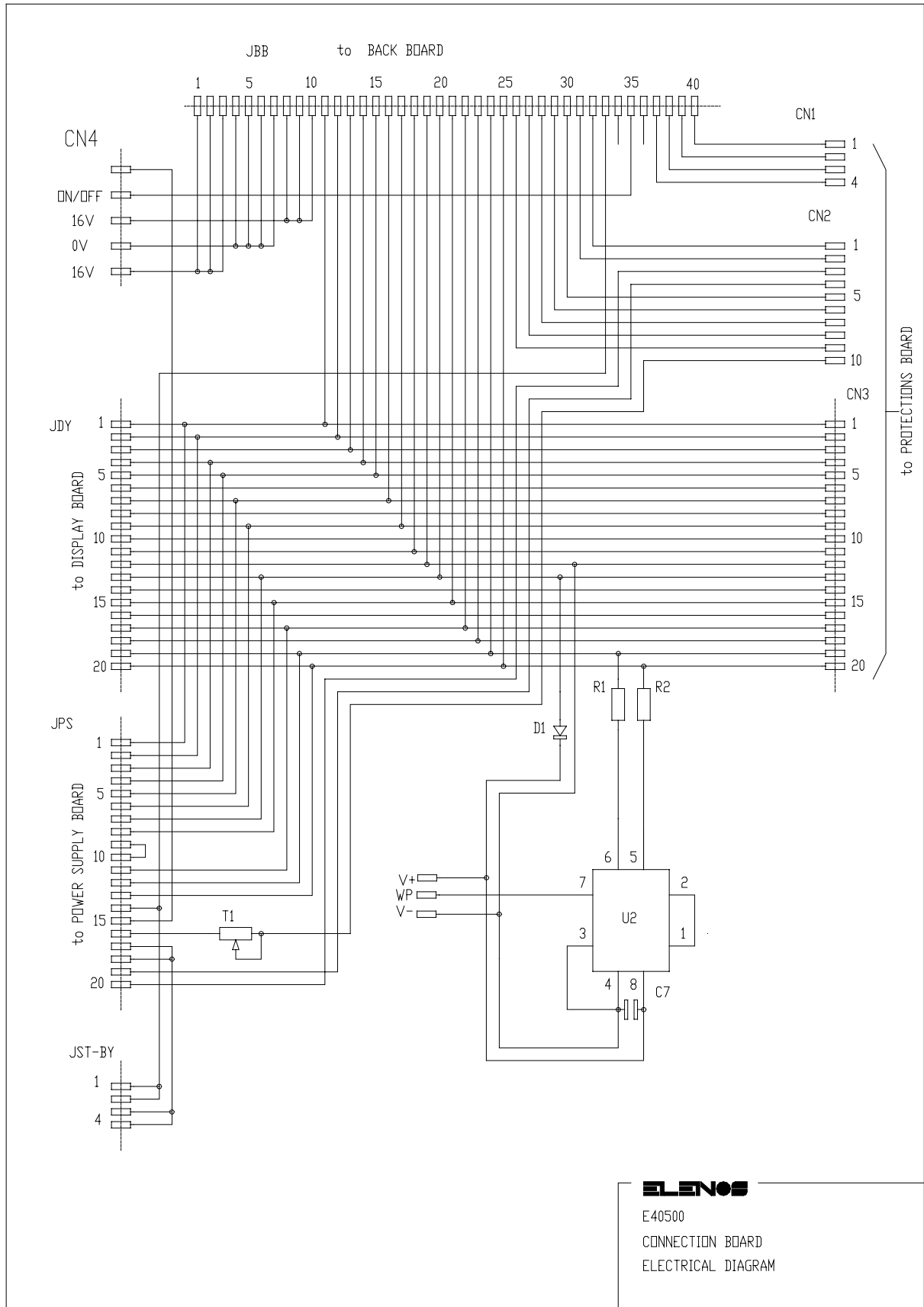

PART LIST BOARD E40500

Rif.	Description	Value	Remarks
PCB	Board code 2PCB0233		
R1, R2	Resistor	100Ω	1/4W 1%
T1	Trimmer type 89P	100KΩ	
C7	Ceramic Capacitor	100 nF	63 V
D1	Diode type 1N4148		
JBB	ANSLEY connector 20+20 pin Straight		
JDY	ANSLEY connector 10+10 pin Straight		
JPS	ANSLEY connector 10+10 pin Straight		
JST-BY	Connector AMP MODU 4 pin Straight 280 371-1		
CN1	Female Strip 2.54 4 pin		
CN2	Female Strip 2.54 10 pin		
CN3	Female Strip 2.54 2 x 10 pin		
CN4	Female Strip 2.54 9 pin		
SK1	DIL Socket 8 pin		

SF000070 - Thermal Probe

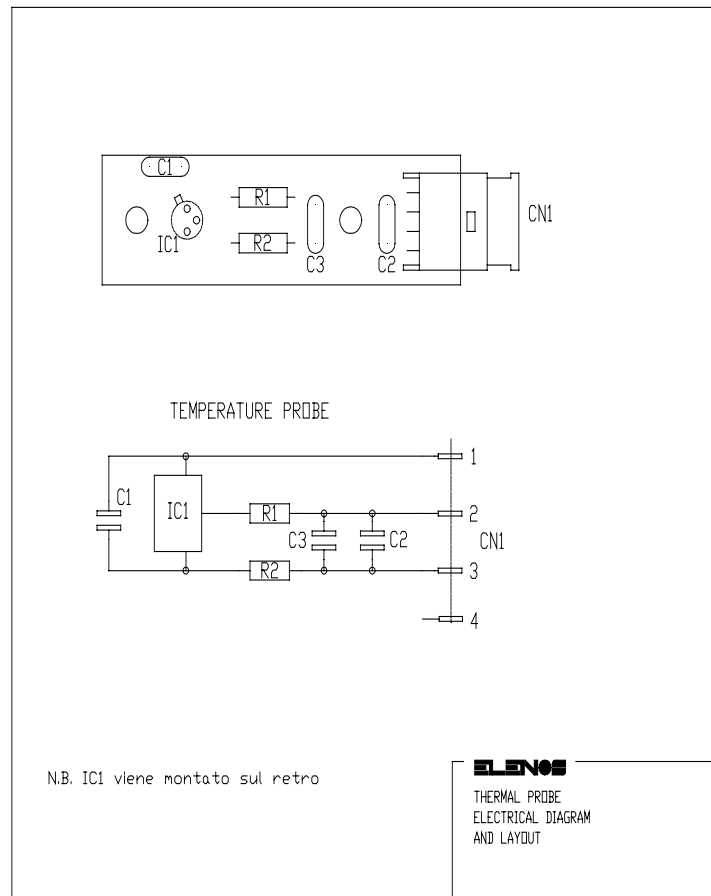

Part List of Thermal Probe Board

Rif.	Description	Value	Remarks
PCB	Board Code 2PCB0208		
R1, R2	Resistor	6980Ω	1/4W 1%
C1, C2	Ceramic Capacitor	4700 pF	
C3	Electrolytic. Capacitor	10 μF	63 V
IC1	Sensor type LM35DH		
CN1	AMP connector 4 pin angled		

**EPCB0200 (Clock Buffer Board)**

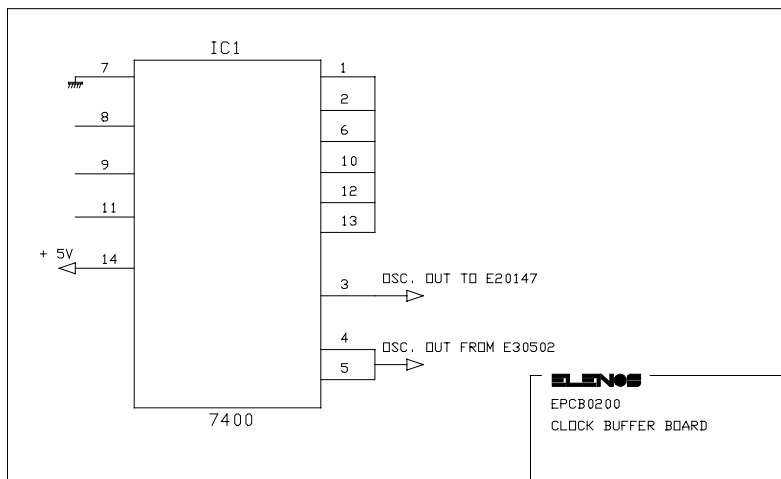
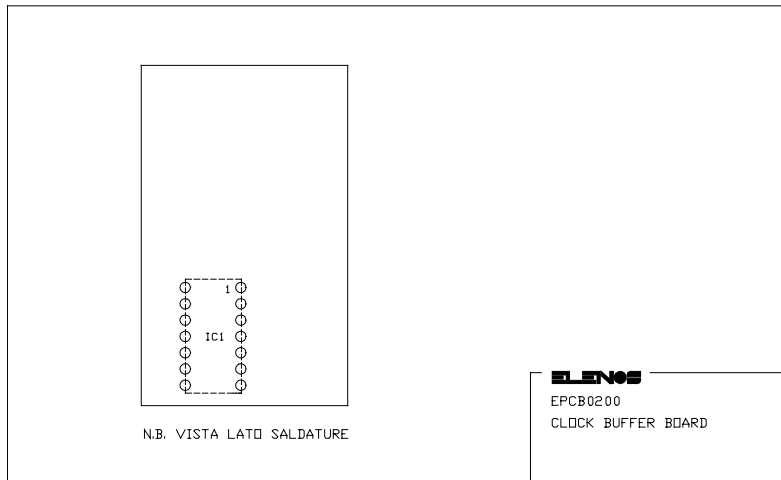

**Part List Board EPCB0200**

Rif.	Description	Value	Remarks
PCB	Board Code 2PCB0200		
IC1	I.C. type DM7400N		

**EPCB0240 ( R.F.I. Protection Board)**

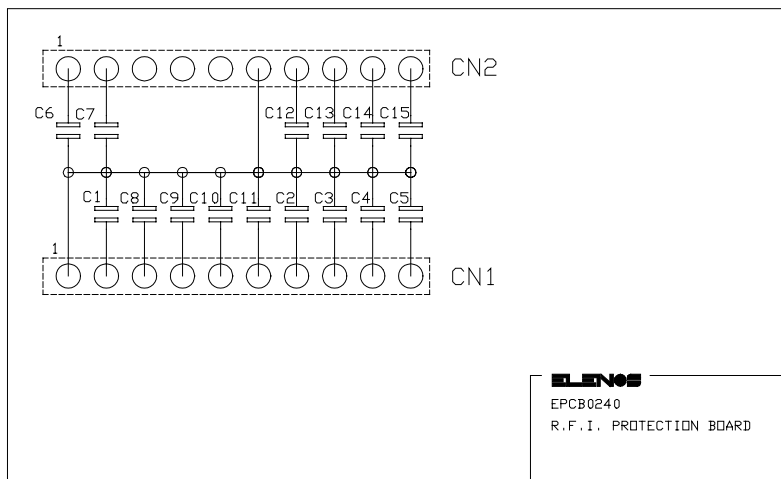
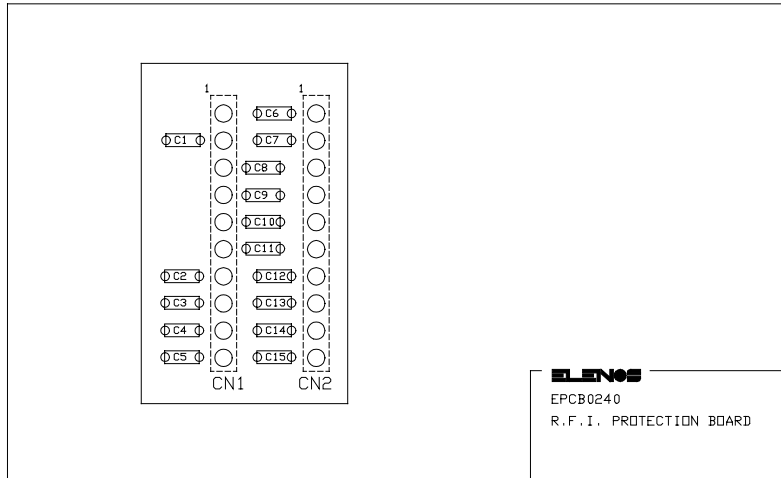

**Part List Board EPCB0240**

Rif.	Description	Value	Remarks
PCB	Board Code 2PCB0240		
C1 - C15	SMD Capacitor	4.7 nF	
CN1, CN2	Strip step 2.54	1 x 10 p	

**EPCB0239 (Watch-Dog Board)**

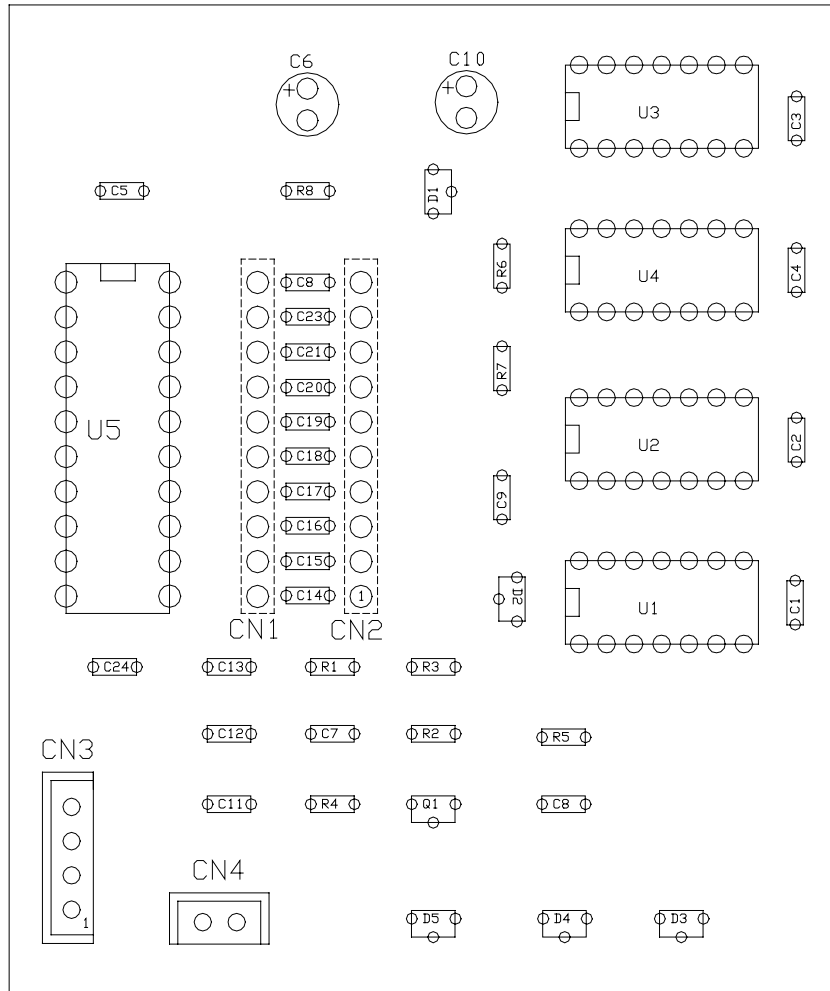

N.B.  
I connettori: CN1, CN2  
vengono montati sul lato saldature

**ELENOS**  
EPCB0239  
WATCH-DOG BOARD



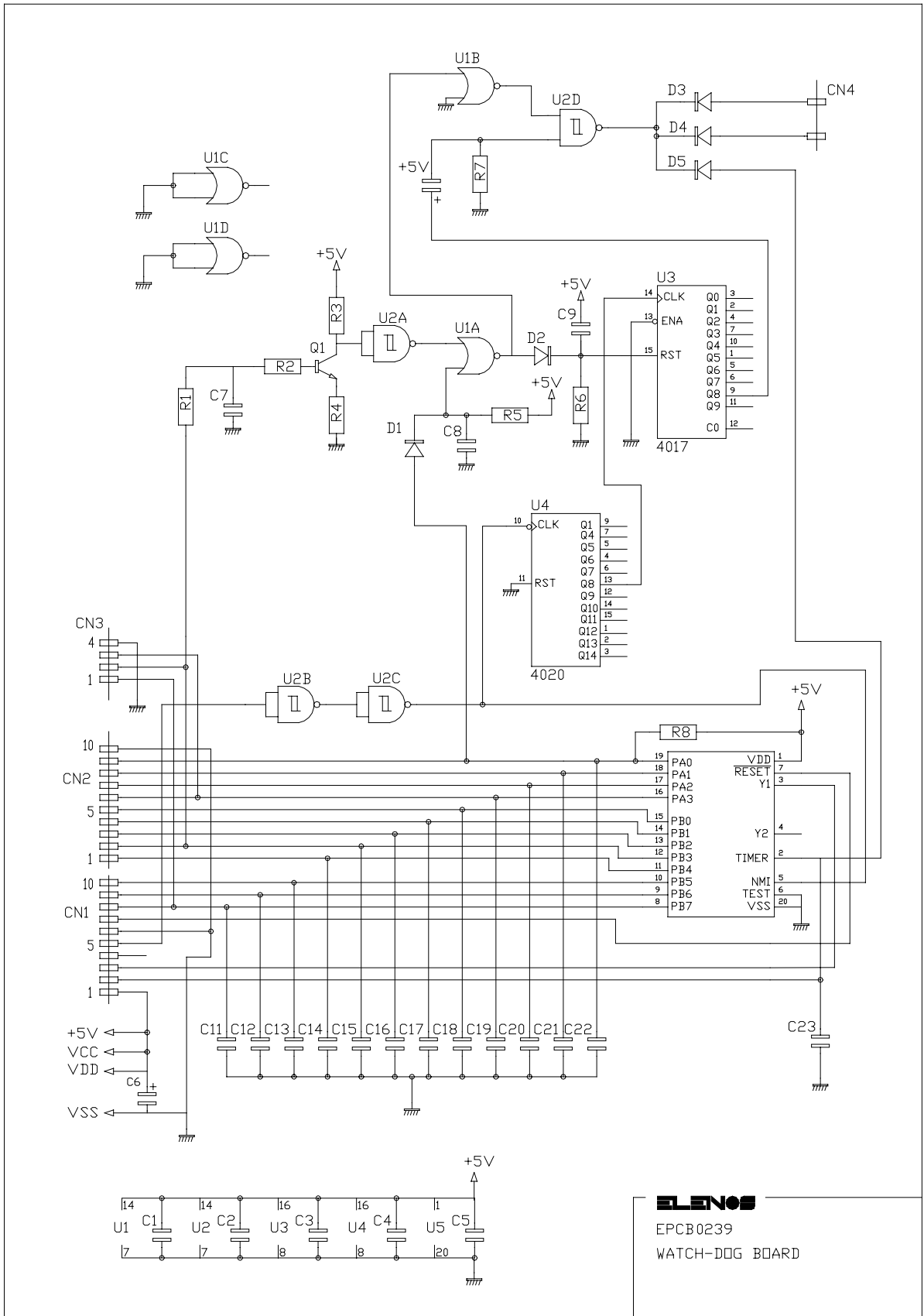

PART LIST BOARD EPCB0239

Rif.	Description	Value	Remarks
PCB	Board Code 2PCB0239		
R1	Resistor	100 K $\Omega$	
R2	Resistor	1 K $\Omega$	
R3	Resistor	10 K $\Omega$	
R4	Resistor	1 K $\Omega$	
R5, R6	Resistor	10 K $\Omega$	
R7	Resistor	100 K $\Omega$	
R8	Resistor	10 K $\Omega$	
C1, C2, C3, C4, C5	SMD Capacitor	100 nF	
C6	Electrolytic Capacitor	22 $\mu$ F	25V
C7	SMD Capacitor	100 nF	
C8	SMD Capacitor	4n7	
C9	SMD Capacitor	470 nF	
C10	Electrolytic. Capacitor	10 $\mu$ F	25V
C11 to C24	SMD Capacitor	4n7	
D1, D2, D3, D4, D5	SMD Diode		
Q1	SMD Transistor		
U1	I.C. type HEF4017BT		
U2	I.C. type HEF4020BT		
U3	I.C. type CD4093BCM		
U4	I.C. type 14077B		
U5	ST62T10B6/HWD + Socket 20p		
CN1, CN2	Strip step 2.54	1 x 10p	
CN3	Connector AMP MODU II 4p straight		
CN4	Connector AMP MODU II 2p straight		